



Liquid Fertilisers Ireland



AGRICULTURE

Product Guide



The OMEX group of companies operate throughout the world manufacturing liquid fertilisers and foliar health promoters for the agricultural, horticultural and amenity sectors. Specialist knowledge of fluid dynamics has also allowed OMEX to expand into producing wastewater treatments and deicers.

The OMEX solution fertiliser range, Nitroflo®, includes some of the most concentrated liquid nitrogen fertilisers available in the UK and Ireland. They are delivered for farmer or contractor application and offer many advantages over conventional solid fertiliser in terms of accuracy, consistency, ease of use, reduced environmental impact and increased yield potential.

www.omex.com

OMEX Agriculture is a major manufacturer of liquid fertilisers and offers the farmer a “Total Crop Nutrition” package through its range of unique suspension fertilisers, solution fertilisers, foliar nutrients, health promoters and SAP testing services.

OMEX Horticulture offers a complete nutrition and advisory service to growers in the soft fruit, top fruit, ornamental, protected salads and turf & amenity sectors.

OMEX Environmental is at the cutting edge of anaerobic digestion, developing bio-available micronutrient supplements to maximise the efficiency of AD plants. OMEX Environmental also develops and markets a range of nutrients and neutralisers for all types of waste water. The company also supplies deicing agents for airport runways, roads, bridges and car parks.

OMEX Agrifluids markets speciality fertilisers in over sixty countries around the world, working

closely with distributors to provide excellent technical solutions to growers. The product range includes foliar fertilisers, plant health promoters, biostimulants, organic fertilisers and soluble powders.

OMEX Agriculture Inc (Canada) manufactures and markets speciality fertilisers throughout Canada and the northern states of the USA. Providing a complete range of seed primers, starters and foliars, the programmed approach to crop nutrition produces maximum yields in short growing seasons.

Agrifluids Inc (USA) based in Selma, California, Agrifluids Inc manufactures a range of foliar fertilisers and fertigation products.

OMEX Agrifluids do Brasil Ltda provides a wide range of crop nutrient products for application via soil, seed and the crop canopy, specialising in crop health promotion and optimising plant nutrition.



CONTENTS

4 Benefits of Nitroflo Liquid Fertiliser

- 4 Summary of Benefits
- 4 Potential Fixed Cost Savings
- 5 Accuracy
- 5 Productivity of Field Margins
- 7 Three Sources of N
- 7 Application

8 Liquid Fertiliser and the Environment

9 Products

- 9 Nitroflo® Range
- 10 Nitroflo® on Grass
- 13 DIDIN®
- 16 Sulphur
- 17 Solution Compound Fertilisers
- 18 Starter Fertiliser

19 Application Information

- 19 Application Charts - Nitroflo Range
- 24 Application Charts - Solution Compounds
- 29 Quick Guide to Converting to Nitroflo Liquid N
- 30 Application Bars and Nozzles
- 31 OMEX Streambar
- 31 Teejet Streamjet SJ7

34 Tank Storage Scheme

- 34 Rental Scheme for 30m³, 40m³ and 50m³ GRP Tank
- 35 Purchase Option for 30m³, 40m³ and 50m³ GRP Tank
- 36 Base and bund requirements for GRP Vertical Tank 30m³/40m³/50m³

37 Notes

- 37 Protecting the Environment - AIC
- 39 Users Code of Practice - AIC
- 47 Notes

Benefits of Nitroflo® Liquid Fertiliser

The OMEX Nitroflo liquid fertiliser range includes some of the most concentrated products available in the UK and Ireland.

They are delivered for farmer or contractor application and offer many advantages over conventional solid fertiliser application in terms of accuracy, consistency and ease of use. By using OMEX Nitroflo liquid fertilisers, farmers save time, protect the environment, and maximise crop yields.

All OMEX liquid fertilisers are supplied in bulk, eliminating packaging and the need to recycle waste, and provide major handling and storage advantages over solid fertilisers.

Summary of Benefits

- Accurate application up to field margins
- Three sources of nitrogen - ammonium, nitrate and urea - so the best balance between availability to crop when needed and reduced risk of loss through leaching
- Effective across a full range of crops, including grass & forage crops
- No off-loading costs as Nitroflo is pumped directly into holding tanks on-farm
- No bag disposal
- Faster response to application on silage ground after first cut, especially in dry conditions
- Improved application accuracy. Tests show that application by granular spreader often vary by 20% across the spread width. Farm sprayers are unlikely to vary by more than 5%
- Better utilisation of time and labour - Nitroflo can be applied in less favourable conditions, when applying solid fertilisers or crop spraying would not be possible
- Higher work rates. It takes just a couple of minutes for one man to load the sprayer with Nitroflo
- An opportunity to upgrade sprayer and increase tramline widths, increasing the cropped area, work rates and accuracy of top-dressing

Potential Fixed Cost Savings

Perhaps one of the best times for a farmer to consider converting to liquid fertiliser is when the farm sprayer or spreader is due for renewal or tramline widths are increased. It is at these points that there is an opportunity to consider the effective utilisation of labour and machinery and the respective fixed costs.

Low-Labour Application System - Liquid fertiliser offers a low-labour application system compared with solid fertiliser:

- No offloading with a forklift
- No storage in a secure building
- No re-loading and carting to field
- No dust, no bag disposal
- No wastage (unused fertiliser is returned to the tank)
- No need for a second man to load the spreader

Low Cost Storage - Low cost GRP storage tanks are available through rental schemes (see pg 34).



"Our OSR was better than any other year. It was the first time we had used Nitroflo and we are sure this made the difference. The crop was even across the field right through to harvest. The crop yielded 2.1t/ac dried to 9% moisture across 100 acres."

Michael Carey, Co Wicklow. Farmer.

Accuracy

Accuracy of Application - The accuracy of application of nitrogen fertiliser has a major impact on gross margins. Variability across a spreading width is referred to as the coefficient of variation (CoV). The graph shows the impact on profitability as the CoV increases for winter wheat. It is not impossible for solid spreaders to operate with CoVs of 30-40% if they are poorly calibrated or

maintained, and 20% is a common average figure. It is only above 20% CoV that striping becomes visible, by which time the financial loss is €20/ha.

Nitroflo is applied by sprayer with an average CoV of 5%, consequently, application of Nitroflo could improve gross margins by €15/ha compared with a spinning disc spreader.

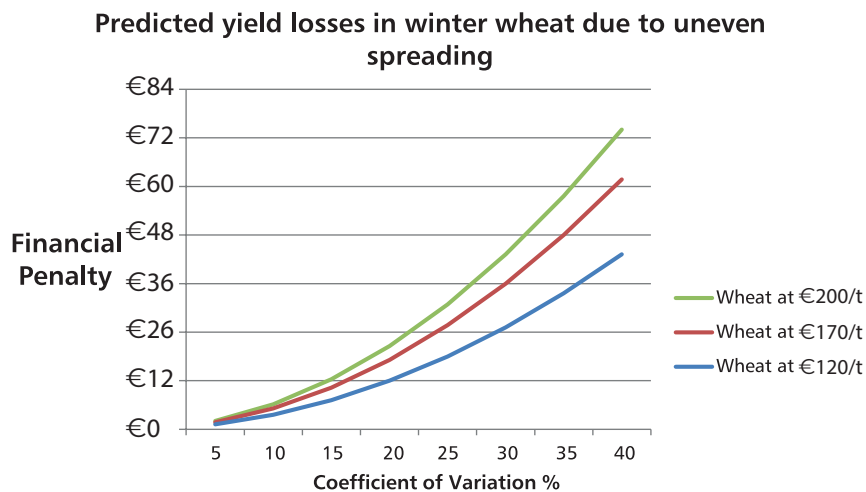

[Ref: IFS Costs and Effects of Uneven Spreading of Nitrogen Fertilisers 2009, Figure 12. Miller, Audsley & Richards]

Productivity of Field Margins

Ensuring nitrogen is applied at full rate to the edge of the field but no further is a key issue. Despite ongoing advances in spreader design, it is not possible for a spinning disc to apply an even distribution pattern if the operator is to guarantee that no fertiliser travels beyond the edge of the field.

Yield loss from the outside 8m of a field has been shown to be 3.5t/ha of winter wheat and 10t/ha of potatoes when nitrogen is applied through a

spinning disc spreader. The outside 8m of a 10ha field represents 5% of the field, so the yield loss would be 1.47t, worth €250 (wheat at €170/t). A farmer growing 400ha of winter wheat could be losing over €4,000 across the outside 8m of his fields.

By using Nitroflo, it is possible to apply the full rate of nitrogen right up to the field margin: no compromise to yield, no risk of applying fertiliser beyond the field margin.

Average Field Size		Yield Loss			
	% Area in Outside 8m	Outside 8m WW (t)	Yield Loss 100ha WW	€ Loss at €170/t	
37ac	15ha	5.00%	3.5	17.5	€2,975
25ac	10ha	5.50%	3.5	19.25	€3,275
20ac	8ha	6.00%	3.5	21	€3,570
12.5ac	5ha	7.50%	3.5	26.25	€4,460
10ac	4ha	8.50%	3.5	29.75	€5,060

"Liquid N? It's a "No Brainer", the best thing I've done for a long time. It is taken up more quickly by the crop, a one-man operation, no striping, and more grass per application."

Mark Jeanes, Lower Bagber Farms Ltd, Dorset. Dairy Farmer.

The visual impact of using solid N on field margins and in split fields, compared to Nitroflo accuracy:

Winter Wheat



Winter Wheat



Grassland



Grassland



Three Sources of N

Replicated plot trials by independent organisations have demonstrated the yield advantage of liquid nitrogen, compared to solid ammonium nitrate and urea. These yield benefits are a result of the blend of nitrogen sources in Nitroflo, which supply a balanced delivery of nitrogen to the crop, along with the superior application accuracy. The visual impact of liquid vs solid application is particularly evident in dry spring seasons when solid nitrogen is less available to the crop when needed.

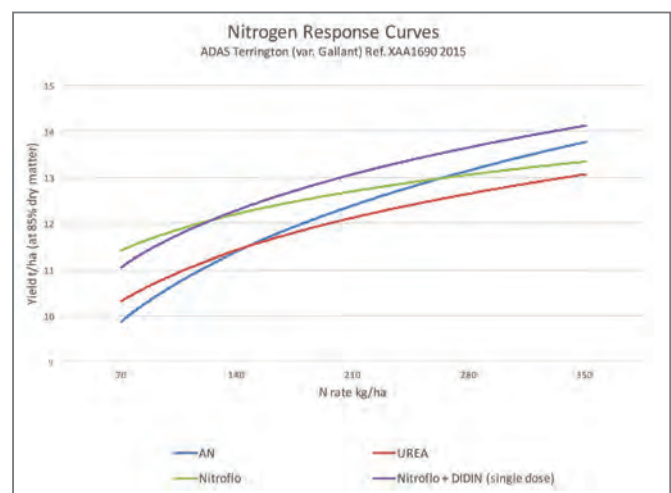

Application

Nitroflo can be applied across a range of weather conditions including situations when solid nitrogen or agrochemicals cannot be applied. Nitroflo can be applied during rainfall, if ground conditions allow. It can be applied in breezy conditions because, unlike spray from a fan jet, the wind will not cause drift of a vertical stream and booms can be lowered to just above crop height. It is best to avoid damp leaf conditions (for example when a dew is lifting) since the nitrogen can spread on the leaf and be absorbed rapidly; in these conditions some scorch is possible.

Less Pollution Risk - By using Nitroflo it is possible to apply the full rate of nitrogen right up to the field margin without losing fertiliser beyond the boundary into the hedge bottom or close to dykes etc. This significantly reduces the risk of polluting water courses without incurring a yield loss along the field margin. Furthermore, since only 25% of the nitrogen sources is nitrate N there is much less risk of leaching shortly after application than with calcium ammonium nitrate (CAN).



This picture was taken by OMEX customer Andrew Burden. Both fields are winter wheat, both had N applied the same day, solid fertiliser was applied to the far field, whilst OMEX Nitroflo was applied to the field in the foreground.

Use Existing Sprayer - Nitroflo can be applied through any farm sprayer. The only conversion required is to fit suitable nozzles. The best jets are those that apply even quantities in vertical streams across the full boom width, because they remove any variability caused by gradient and boom height. Consequently OMEX recommends the OMEX Streambar.

Nitrogen & Sulphur Together - By using one of the Nitroflo-S formulations, the farmer can apply nitrogen & sulphur together. The sulphur is included in sulphate form making sure both nutrients are available when needed. The range of sulphur grades allow the farmer to fine tune the sulphur application in season if required.

More Crop Available in Dry Conditions - As soon as Nitroflo is applied it is drawn into the soil. So, even in the driest of springs nitrogen starts becoming available to plants shortly after application.

Application Guidelines

Do	Don't
Do apply when the crop is wet or in the rain	Don't apply when the crop is just damp and drying off – this may lead to a smear of nitrogen drying on the leaf, leading to too much leaf uptake
Do apply in the dry	Don't apply in wind once feathers of small droplets are being blown from the main stream, or if the wind has caused leaf bruising
Do apply in wind so long as streams are not being deflected by wind	Don't go above 2 bar pressure unless you really have to
Do keep forward speed slow and pressure low	Don't apply in the heat of the day or when >20°C between max and min is expected
Do apply in the evening or early morning if possible	Don't apply to the flag leaf (or leaf 2 if possible)
Do plan to complete your applications by GS32 (2nd node on stem detectable) on cereals	In sequence: Don't apply agrochemicals first – they are likely to de-wax the leaves and increase to risk of foliar uptake of N. Leave a 5 day gap if possible
In sequence: Do apply fertiliser first and agrochemicals second. Leave a 2 day gap if possible	Don't dilute liquid nitrogen, it increases the risk of scorch
Do keep grazing stock out for 5 days if there has been no rain	

Liquid Fertiliser and the Environment

Liquid nitrogen fertilisers offer great advantages with easy and accurate application and they are based on a non-hazardous solution of ammonium nitrate, ammonium sulphate and urea. The different nitrogen sources give a range of nitrogen release characteristics to crops. The nitrate content is immediately available, the urea content takes a little time to convert to nitrate and the ammonium content is somewhere in between. The plant-available nitrogen is therefore released more slowly than from nitrate-based products, reducing the risk of nitrate leaching and nitrous oxide losses during wet times and in waterlogged soils.

Nitrous oxide is a powerful greenhouse gas and can also break down to nitrogen oxides that can result in ozone depleting reactions (breaking down the ozone layer). Nitrous oxide has a global warming potential around 300 times greater than carbon dioxide, but unlike carbon dioxide, there is no natural absorption of nitrous oxide so it can remain in the atmosphere for hundreds of years.

The use of liquid nitrogen can therefore reduce the risk of nitrous oxide emissions, reducing the risk of global warming and nitrate leaching, reducing the risk of groundwater pollution.

The urea content of liquid nitrogen may be thought to have a potential to lose ammonia gas (volatilisation), a common issue with solid urea. The risk is much lower with liquid nitrogen as the urea is already dissolved, so enters and is drawn into the soil, protecting it from the risk of losses.

Liquid nitrogen plus sulphur therefore offers one of the best options in terms of accuracy of application, prevention of pollution of field margins and protection from nitrogen losses. However, if there are localised concerns about the specific risk of nitrate leaching or ammonia volatilisation, liquid nitrogen offers the flexibility to tank mix nitrification inhibitors (to delay the release of nitrate) and urease inhibitors (to delay the production of ammonium nitrogen) if required.

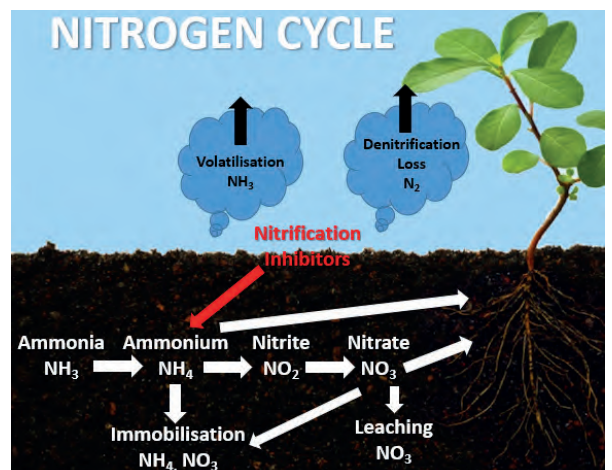

Products - OMEX Nitroflo® Range

All fertilisers, including liquids, have to be invoiced by a guaranteed weight. Therefore, and to avoid confusion, all OMEX fertilisers are sold by weight and easy to use conversion charts are provided to give application volumes.

The range includes:

Nitroflo 30 - the most concentrated liquid nitrogen. The nitrogen source in Nitroflo is UAN - 50% of N sourced from urea, 25% from ammonium N and 25% from nitrate N.

Nitroflo 26+S - containing nitrogen and sulphur; for top-dressing sulphur responsive crops in the spring during periods of rapid growth. The sulphur source is sulphate.

Nitroflo 24+S - containing nitrogen and a higher level of S than Nitroflo 26+S. The sulphur source is sulphate.

Nitroflo 22+S - containing nitrogen and a higher level of S than Nitroflo 24+S. The sulphur source is sulphate.

Nitroflo 20+S - containing a higher level of sulphur; for deficient areas and crops with a high demand for sulphur, such as oilseed rape. The sulphur source is sulphate.

Nitroflo 30+DIDIN - allows growers to use just a single application to meet a crop's entire nitrogen requirement, saving application costs, improving yields and reducing nitrogen losses.

For application charts see page 19, or ask for a copy of the handy application chart

Product	Analysis w/w		SG	Approx Analysis w/v		
	N	S		N	S	
Nitroflo 30	30%		1.30	39%		390kg/1000 litre
Nitroflo 26+S	26%	2%	1.28	33.3%	2.5%	333kg N + 26kg S/1000 litre
Nitroflo 24+S	24%	3%	1.27	30.5%	4%	307kg N + 38kg S/1000 litre
Nitroflo 22+S	22%	4%	1.26	28%	5%	279kg N + 50kg S/1000 litre
Nitroflo 20+S	20%	5%	1.25	25%	6%	252kg N + 63kg S/1000 litre
Nitroflo 30+Didin	30%		1.30	39%		390kg N/1000 litre + Didin



Nitroflo[®] on Grass

Nitroflo can be used instead of solid N on all types of grass. These are the key advantages:

- Post cut or grazing, grass will respond to Nitroflo more quickly than solid N
- Daily gain in dry matter is larger when using Nitroflo
- Even in drought conditions new growth following uptake of N can be seen within 36 hours
- All the benefits of accurate application still apply in grass
- Nitroflo S contains sulphur in a form that is immediately plant available

Nitroflo S v Urea

A New Zealand style grazing dairy unit in Staffordshire applied OMEX Nitroflo S on the same day as urea on adjoining grazing paddocks. The pictures below, taken at the same time, show the difference in DM production following application of Nitroflo Liquid Nitrogen.

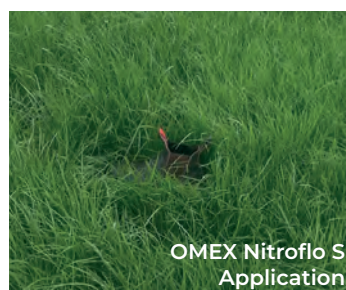

Silage Grass

Leamlara, Co. Cork, 2018 - The picture sequence below shows a field after second cut silage. The crop was cut on 16 July, picked on 17 July, then grazed for two days. On 20 July OMEX Nitroflo S was applied at a rate of 112kg/ha N (90 units/ac). Despite the drought, uptake of N was very rapid and a visual difference could be seen within two days.

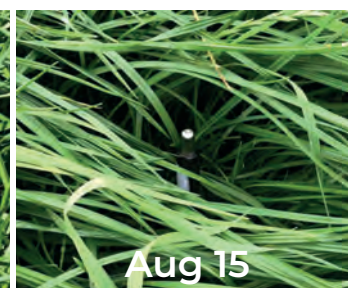
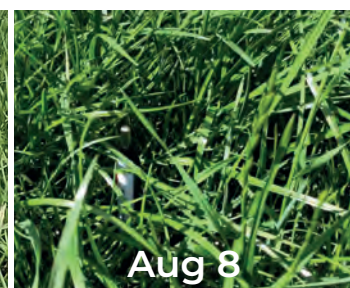
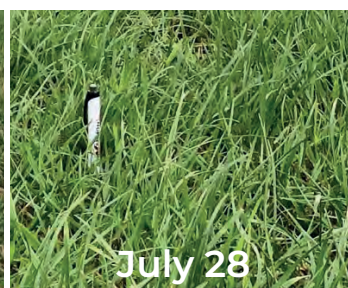
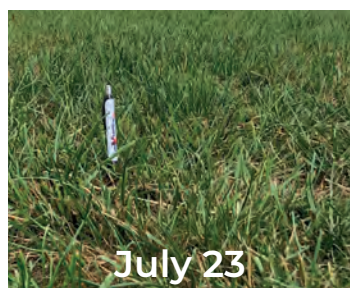

"I used Nitroflo 26S for the first time this year. I liked the accuracy across the field and no overlapping the ins and outs with auto-shutoff. I noticed far less secondary growth in my spring malting barley compared with what I saw in crops that had solid. I put this down to the more rapid uptake in dry conditions. We also saw fast regrowth on 2nd cut silage.

The tank installation guys were very efficient and professional. The fact that the liquid is stored in its own tank is fantastic as it doesn't take up shed space during the season."

Paul Mernagh, Coolamurry Farms Ltd. Co. Wexford. Farmer.

OMEX Nitroflo® vs SulfaCAN

South Tipperary- June 2020

Two paddocks Perennial Ryegrass, both reseeded on the same day.

9th of June	LHS - 27 units/ac SulfaCAN	RHS - 25 units/ac Nitroflo 26S
<p>After 14 days: 53% more grass with less units of nitrogen</p>		
	LHS - SulfaCAN	RHS - Nitroflo 26S
Units/acre of Nitrogen	27	25
Quadrant	190g	340g
DM%	15.58	14.24
Kg / Ha	1260	1936
Days growth Post fertiliser	14	14
Growth/day-Kg DM	90	138
M.E. MJ/KgDM	11.84	12.13
Protein %	23.7	25.13
DMD%	79.37	81.15

OMEX Nitroflo® vs Protected Urea

North Tipperary- July 2020

Two paddocks side by side of Perennial Ryegrass.

4th of July	LHS - 27 units/ac Protect Urea	RHS - 27 units/ac Nitroflo 26S
<p>After 14 days: 65% more grass with same units of nitrogen</p>		
	LHS	RHS
Units/acre of Nitrogen	27	27
Quadrant	170g	280g
DM%	15	14
Kg / Ha	1020	1680
Days growth Post fertiliser	14	14
Growth/day-Kg DM	77.85	120

OMEX Nitroflo 26S on Silage Ground

Co. Laois – June 2020

Nitroflo 26S applied to 2nd cut silage stubble:



Nitroflo 26S applied 22 June 2020



Same crop 16 DAT on 9 July 2020

Grassland Trial

Co. Wicklow – May to July 2020

Type of Fertiliser	Granular Fert (24-2.5-10)	OMEX Nitroflo 26N+2S	
Field Name	Tuttys	Mileys	
Application date	18/05/2020	22/05/2020	
Rate N applied	65 units/ac	60 units/ac	
Growth Kg DM/Ha/Day	Growth Kg DM/Ha/Day	Growth Kg DM/Ha/Day	Conditions
Kg DM/HA day Week 1	18.76	37.45	Drought
Kg DM/HA day Week 2	53.36	44.16	Heavy rain
Kg DM/HA day Week 3	53.88	67.02	Rain
Average Growth Kg DM/HA/ day	42.00	49.54	+ 18%
Total Growth Kg DM/HA/ (21 days)	882.00	1,040.41	+ 58 Kg
Kg DM/HA day Week 4	112.00	93.00	
Kg DM/HA day Week 5	98.42	96.85	
Kg DM/HA day Week 6	75.00	74.00	
Average Growth Kg DM/HA/ day	68.60	68.70	
Total Growth Kg DM/HA (42 days)	2,879.94	2,887.36	
Note:	Both fields received slurry at 2500g/ac		

Summary

- Twice the growth from Nitroflo in week 1 during dry conditions
- After three weeks, 18% more growth with Nitroflo
- After six weeks same kg DM/ha from 8% less N using Nitroflo

DIDIN is a unique nitrogen stabiliser. When added to fertiliser or organic manures and applied to the soil it controls the release of crop-available nitrogen. It allows nitrogen to be applied in a single dose, eliminating the need for repeated applications, saving both time and money. It increases yields and dramatically improves the value of winter-applied slurry and AD digestate.

- Reduces growing costs
- Reduces nitrate leaching
- Improves value of slurry
- Improves yield and quality
- Simplifies nitrogen management
- Reduces the carbon footprint of applications

Trial Results and Yield Benefit

Trials by a wide range of organisations over many years have shown consistent yield advantages in crops treated with DIDIN. By including DIDIN with any nitrogen applications, the nitrogen is used more efficiently by the crop helping improve yield and quality by reducing nitrogen losses and optimising nitrogen delivery to the crop.

Crop	Number of trials	Average yield increase - t/ha	Average yield increase - %
Silage Maize	8	6.40	13.6%
Sugar Beet	19	1.80	3.0%
Potatoes	23	6.24	10.0%
Cereals	16	0.45	7.7%
Grassland	8	0.60	13.3%

DIDIN in the Soil

Ammonium and urea based nitrogen fertilisers need bacteria to convert them from being relatively immobile to the highly mobile and plant available nitrate form. DIDIN inhibits the activity of the soil bacteria that convert this ammonium-N into nitrate-N, helping reduce nitrate leaching and creating a phased release of crop available nitrogen. As soil temperatures increase and crop growth begins, DIDIN progressively releases more nitrate nitrogen into the soil. After the inhibition has ceased the DIDIN is totally converted to plant-available nitrogen, leaving no residues in the soil.

DIDIN for Grass

Silage grass – DIDIN can be used with most sources of nitrogen. For best use tank mix with OMEX Nitroflo. Apply all early spring N in one go as Nitroflo + DIDIN. After 1st cut, apply all the N for 2nd and 3rd cut as Nitroflo and DIDIN.

Grazing grass – The number of repeat applications can be reduced by applying two doses at once with DIDIN. This reduces the cost of applications but maintains a constant feed of N to the crop.

DIDIN with Organic Manures and AD Digestate

DIDIN helps convert slurry, manure and the digestate from anaerobic digestion from being waste products into valuable fertilisers. It conserves the nitrogen through the late winter/ early spring, reducing the risk of nitrate leaching and phases the release of nitrate during the following spring and summer, reducing the requirement for additional nitrogen top-dressing. It also helps reduce losses of nitrous oxide following de-nitrification in waterlogged soils and increases crop yield and quality.

DIDIN for Maize

When using Nitroflo on maize, apply all the N pre-drilling or pre-emergence with DIDIN. This works well when maize is being grown under polythene.



Silage grass treated with Nitroflo plus Didin

DIDIN for Cereals

A single top-dressing with DIDIN allows the full season's nitrogen requirement to be applied in one simple application, at any time from the end of January to the end of March. The nitrogen is gradually released as plant-available nitrate at a rate at which the crop can use it. Leaching losses of nitrate are minimised and the risk of denitrification losses of nitrous oxide is also significantly reduced. Since the nitrate for the crop is released from the

soil, crop nutrition is maintained at an ideal level, regardless of dry or wet conditions. Conventional applications may remain on the surface in dry conditions, leading to nitrogen deficiency. In conditions when it is too wet to apply nitrogen the crop can also become deficient. With DIDIN, the nitrate is released gradually and consistently through all conditions, maintaining crop growth.

Extensive trials on winter wheat have shown that, in addition to application cost savings, the single nitrogen application with DIDIN produces an average yield increase of 0.5 t/ha, compared to split nitrogen application.

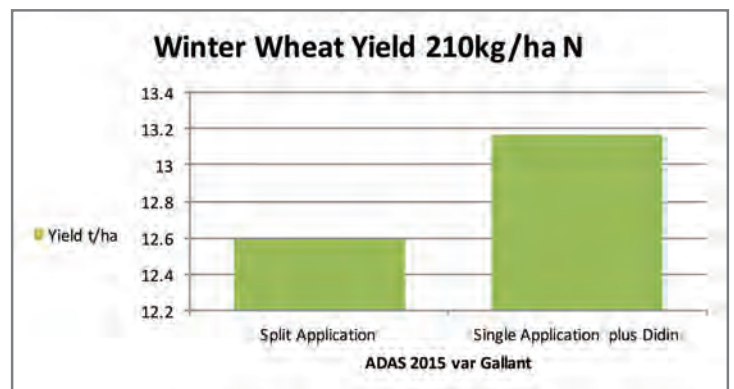

The field of winter oats below, received 120kg/ha of N with Nitroflo. The left half as a split dose, the right half as a single dose with DIDIN. On assessment, both halves are at the same growth stage, the difference is the flag leaves of the DIDIN treated half were on average 5cm longer and also wider.



DIDIN for Potatoes

Potatoes respond particularly well to application of stabilised nitrogen since most of the crop nitrogen requirement is applied immediately prior to planting. Crop uptake of the nitrogen does not start until 6-8 weeks later and, during wet spring conditions, some of the nitrogen applied can be leached beyond the shallow crop roots. The crop

is also often heavily irrigated and the use of DIDIN helps prevent nitrate nitrogen being leached by excessive rates of irrigation.

In UK trials over six years DIDIN treated potatoes have consistently outperformed conventionally treated crops. The marketable yield increase is 11%, with a significant return on investment.

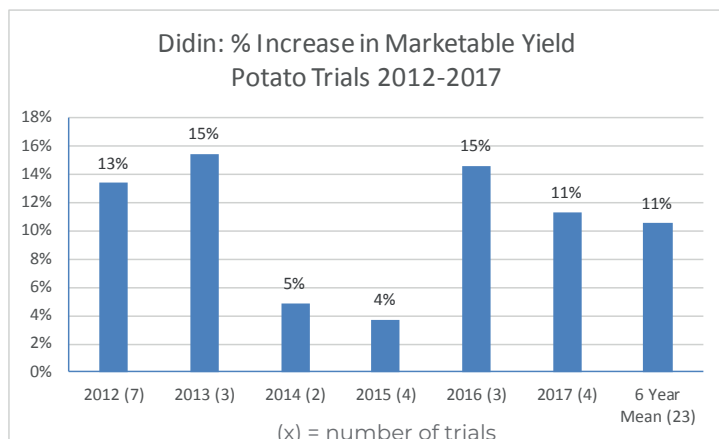

Additional Cost, Didin 10 l/ha	€ 50/ha
Mean Additional Marketable Yield	6.235 t/ha (+10%)
Value of additional Yield	€842/ha*
Increased Profit	€ 792/ha
Return on Investment	16:1

23 trials over 6 years (2012-2017), 13 varieties

* Ex farm average price €135/€

DIDIN Directions for Use

Liquid Fertiliser: Add half the fertiliser to the spray tank, add the required amount of DIDIN whilst agitating. Add the remaining fertiliser and maintain agitation whilst spraying.

Granular Fertiliser: Apply before application of granular fertiliser using spray nozzle. Apply in a minimum of 200L/ha water.

Organic Manures: Ensure the DIDIN and slurry are well mixed. If using an umbilical cord system use a proportional injection system. If using a slurry tanker add DIDIN during filling. Didin can also be sprayed on before spreading the organic manure.

Type of Fertiliser/Crop	Timing	Soil Type	Rate
Liquid Nitrogen Fertiliser/Ammonium Nitrate	Spring	Light Medium Heavy/Peat	12.5L/ha 10L/ha 8L/ha
Granular/Prilled Urea	Spring	Light Medium Heavy/Peat	10L/ha 6L/ha 6L/ha
Liquid Fertiliser on Potatoes - Broadcast - Injected	Spring Spring	Light Light	12.5L/ha 6L/ha
Organic Manures, Slurry and AD Digestate on Arable Crops	Autumn Winter Spring		20-25L/ha 15-20L/ha 10-15L/ha
Organic Manures, Slurry and AD Digestate on Grass	Autumn Winter Spring		15-20L/ha 10-15L/ha 10L/ha

Sulphur

Sulphur is a vital element for plants and is required in similar amounts to phosphate in most crops.

Sulphur deposition has decreased dramatically over the last 30 - 40 years due to emission controls. Deficiencies of this vital element are now visible in many crops and current atmospheric deposition is estimated at less than 4 kg/ha sulphur per year throughout most of Ireland, so most crops will benefit from applications of fertiliser containing sulphur.

Responses to sulphur vary according to soil type, with greater responses likely on light or sandy soils. The level of response is affected by over winter rainfall on loam and coarse silty soils, with high rainfall increasing the likelihood of a significant yield increase. Clay, fine silts and organic soils have a lower likelihood of yield responses, except in areas with medium to high winter rainfall, where there is a medium chance of a yield response.

How much to Apply

The continued reduction in sulphur deposition means that many rural areas in Ireland currently only receive less than around 4 kg/ha of S from the atmosphere. The following recommendation take this into account.

Oilseed Rape

Most oilseed rape crops require a minimum 40kg/ha S sulphur.

Cereals

Cereals require approximately 25kg/ha S of sulphur

Maize

Historically, maize was grown in rotations with often large inputs of manure and slurry, which usually provided sufficient sulphur for the crop. With maize being increasingly grown outside livestock areas it is important to consider the sulphur requirement of the crop with an application of 20-30 kg/ha S particularly on light soils.

Vegetables

Most brassica crops have a relatively high requirement for sulphur and adequate levels of sulphur are required for improved taste in a number of vegetable crops. Sulphur is also required to ensure efficient nitrogen utilisation in vegetable crops, with deficiency often resulting in reduced nitrogen responses. Application of 15 kg/ha S is recommended in responsive situations.

Grassland

Sulphur deficiency reduces the yield and quality potential of grassland and is exacerbated by high forage removal rates. Responsive crops require approximately 15 kg/ha S. Top-dressing with Nitroflo S provides immediately available sulphur to supply the crops needs.



Sulphur deficiency (right) in oilseed rape



Sulphur deficiency in winter wheat

Solution Compound Fertilisers

OMEX solution compound fertilisers are true compounds; every drop contains the complete analysis. They cannot segregate and as a result every square centimetre of soil is guaranteed to receive the required ratio of nitrogen, phosphate and potash. Solution compounds are ideal for placement on potatoes and other crops, where the fertiliser can be very accurately placed in the soil.

NPK Solutions

The OMEX solution compound range offers accurate application of fertiliser for a wide range of situations, from pre-drilling to post-emergence. Most requirements can be supplied from the standard range of compounds, however OMEX also offers a custom blending service, providing an almost infinite range of analyses if necessary.

NPK+S Solutions

OMEX solution compounds can also be supplied containing sulphur. Since the inclusion of S dilutes the NPK, the maximum inclusion rate is limited to 2S.

Placement

The close positioning of fertiliser in relation to crop roots can have a significant effect on the nutrient use efficiency of the fertiliser. Placement with solution fertilisers offers significant advantages over solid placement; precision positioning is guaranteed and the nutrients are all fully dissolved, offering rapid crop response. Handling is minimised, with pumps carrying out all transfers without bag handling and disposal. Placement of liquid compound fertiliser on potatoes can increase yields by 10-15%. Liquid nitrogen placement for vegetable and salad row crops results in more rapid and even establishment of transplants and provides prolonged nitrogen response for long-season crops. Starter doses of nitrogen and phosphate for crops such as maize can dramatically improve establishment rates.

Starter Fertiliser

Liquid nitrogen, with or without phosphate, applied with cultivation drills and sub-soilers can significantly improve the establishment of maize or oilseed rape and phosphate can help enhance rooting. Since the phosphate is fully water soluble it is more accessible to the plant at the peak time for early root development. Application of low doses of nitrogen and phosphate helps establishment but does not remove the need to replace nutrients taken up throughout the life of the crop, otherwise soil reserves will be depleted.

Combined Drilling with Liquid Fertiliser

Most modern drills can be adapted to allow a liquid fertiliser applicator to be fitted, providing the opportunity to place starter fertiliser in the row or surrounding the seed of any drilled crop. OMEX NPK solutions can be applied alone or in conjunction with micronutrients or phosphites, as required by the crop. The system allows for complete flexibility whilst providing the best possible environment for plant establishment.

Precision Farming

OMEX solution fertilisers offer the ideal fertiliser delivery system for variable rate application. Modern flow controllers can simply be upgraded to provide variable rate fertiliser application, based on application maps from a number of sources; active crop sensors, remote sensing, soil testing or from an agronomist's field experience. Many of the UK's most innovative precision farmers use liquid fertilisers due to the ease of controlling the application rates and the ability to automatically regulate individual boom sections.

Starter Fertilisers

Minimum cultivation establishment techniques for oilseed rape offer an ideal opportunity to place a starter fertiliser in the root zone of the establishing plant.

To ensure that a crop gets off to a good start, it needs feeding. The best way to do this is to place a starter fertiliser precisely where it is required, effectively creating a nutrient rich seedbed for the crop. OMEX solution fertilisers offer the most effective means of accurately placing nutrients with 100% solubility in the right place for the emerging seedling.

OMEX liquid starter fertilisers are also ideal for placement on drills for other crops, such as cereals, maize, and sugar beet.

Products and Recommendations

Tables below show application rates in l/ha to apply 30-60kg/ha of N (24-48 units/ac):

Nitroflo 30: contains 39 kg nitrogen per 100 litres product. For use where only nitrogen is required.

OMEX 17-3.5-0: contains approximately 21 kg nitrogen and 4 kg phosphorus per 100 litres product. For use where a phosphate starter effect is required.

Nitroflo 30		Percent of Field Covered by Fertiliser Bands				
kg/ha Applied In the Band		10%	20%	25%	33%	50%
N	P	Application rate l/ha				
30		8	15	19	31	38
40		10	21	26	34	51
50		13	26	32	42	64
60		15	31	38	51	77
Nitroflo 30N		39 kg N per 100 litres of product				

17-3.5-0		Percent of Field Covered by Fertiliser Bands				
kg/ha Applied In the Band		10%	20%	25%	33%	50%
N	P	Application rate l/ha				
30	6	14	29	36	57	71
40	8	19	38	48	63	95
50	10	24	48	60	79	119
60	12	29	57	71	94	143
17-3.5-0		21 kg N & 4 kg P per 100 litres of product				

Advantages of OMEX liquid starter fertilisers

- Major saving in autumn nitrogen requirement, up to 75%
- All of nitrogen captured by crop, reducing risk of leaching loss
- Fully soluble phosphate
- No dust, no blockages
- Precise targeting of nutrients
- Flexibility to work well within NVZ nitrogen limits
- Available with Polymex

OMEX 14-6-0: contains approximately 17 kg nitrogen and 7.5 kg phosphorus per 100 litres product. Provides greater starter effect.

OMEX 7-9-0: contains approximately 9 kg nitrogen and 11 kg phosphorus per 100 litres product. Traditional starter fertiliser, provides full starter rate of phosphate.

14-6-0		Percent of Field Covered by Fertiliser Bands				
kg/ha Applied In the Band		10%	20%	25%	33%	50%
N	P	Application rate l/ha				
30	13	18	35	44	71	88
40	17	24	47	59	94	118
50	22	29	59	74	118	147
60	26	35	71	88	141	176
14-6-0		17 kg N & 7.5 kg P per 100 litres of product				

7-9-0		Percent of Field Covered by Fertiliser Bands				
kg/ha Applied In the Band		10%	20%	25%	33%	50%
N	P	Application rate l/ha				
30	39	33	67	83	110	167
40	51	44	89	111	147	222
50	64	56	111	139	183	278
60	77	66	134	166	220	334
7-9-0		9 kg N & 11 kg P per 100 litres of product				

Application Information

Application Chart Nitroflo 30: 30% N

kg/ha N	units/ac N	l/ha	galls/ac
25	20	64	6
30	24	77	7
35	28	90	8
40	32	103	9
45	36	115	10
50	40	128	11
55	44	141	13
60	48	154	14
65	52	167	15
70	56	180	16
75	60	192	17
80	64	205	18
85	68	218	19
90	72	231	21
95	76	244	22
100	80	256	23
105	84	269	24
110	88	282	25
115	92	295	26
120	96	308	27
125	100	321	29
130	104	333	30
135	108	346	31
140	112	359	32
145	116	372	33
150	120	385	34
155	124	397	35
160	128	410	37
165	132	423	38
170	136	436	39
175	140	449	40
180	144	462	41
185	148	474	42

Specific Gravity (SG): 1.30

Please note that the SG varies slightly with temperature

Apply with appropriate nozzles

Avoid application during very windy weather or when the leaf is damp

Do not apply on a rime frost or following severe frost

Application Chart Nitroflo 26+S: 26%N + 2%S

METRIC			IMPERIAL		
kg/ha N	kg/ha S	l/ha	units/ac N	units/ac S	galls/ac
25	2	75	20	2	7
30	2	90	24	2	8
35	3	105	28	2	9
40	3	120	32	2	11
45	3	135	36	3	12
50	4	150	40	3	13
55	4	165	44	3	15
60	5	180	48	4	16
65	5	195	52	4	17
70	5	210	56	4	19
75	6	225	60	5	20
80	6	240	64	5	21
85	7	255	68	5	23
90	7	270	72	6	24
95	7	285	76	6	25
100	8	300	80	6	27
105	8	316	84	6	28
110	8	331	88	7	29
115	9	346	92	7	31
120	9	361	96	7	32
125	10	376	100	8	33
130	10	391	104	8	35
135	10	406	108	8	36
140	11	421	112	9	37
145	11	436	116	9	39
150	12	451	120	9	40
155	12	466	124	10	41
160	12	481	128	10	43
165	13	496	132	10	44
170	13	511	136	10	45
175	13	526	140	11	47
180	14	541	144	11	48
185	14	556	148	11	49

Specific Gravity (SG): 1.28

Please note that the SG varies slightly with temperature

Apply with appropriate nozzles

Avoid application during very windy weather or when the leaf is damp

Do not apply on a rime frost or following severe frost

Application Chart Nitroflo 24+S: 24%N + 3%S

METRIC			IMPERIAL		
kg/ha N	kg/ha S	l/ha	units/ac N	units/ac S	galls/ac
25	3	82	20	3	7
30	4	98	24	3	9
35	4	115	28	4	10
40	5	131	32	4	12
45	6	148	36	5	13
50	6	164	40	5	15
55	7	180	44	6	16
60	8	197	48	6	18
65	8	213	52	7	19
70	9	230	56	7	20
75	9	246	60	8	22
80	10	262	64	8	23
85	11	279	68	9	25
90	11	295	72	9	26
95	12	312	76	10	28
100	13	328	80	10	29
105	13	344	84	11	31
110	14	361	88	11	32
115	14	377	92	12	34
120	15	394	96	12	35
125	16	410	100	13	37
130	16	427	104	13	38
135	17	443	108	14	39
140	18	459	112	14	41
145	18	476	116	15	42
150	19	492	120	15	44
155	19	509	124	16	45
160	20	525	128	16	47
165	21	541	132	17	48
170	21	558	136	17	50
175	22	574	140	18	51
180	23	591	144	18	53
185	23	607	148	19	54

Specific Gravity (SG): 1.27

Please note that the SG varies slightly with temperature

Apply with appropriate nozzles

Avoid application during very windy weather or when the leaf is damp

Do not apply on a rime frost or following severe frost

Application Chart Nitroflo 22+S: 22%N + 4%S

METRIC			IMPERIAL		
kg/ha N	kg/ha S	l/ha	units/ac N	units/ac S	galls/ac
25	5	90	20	4	8
30	5	108	24	4	10
35	6	126	28	5	11
40	7	144	32	6	13
45	8	162	36	7	14
50	9	180	40	7	16
55	10	198	44	8	18
60	11	216	48	9	19
65	12	234	52	9	21
70	13	253	56	10	22
75	14	271	60	11	24
80	15	289	64	12	26
85	15	307	68	12	27
90	16	325	72	13	29
95	17	343	76	14	31
100	18	361	80	15	32
105	19	379	84	15	34
110	20	397	88	16	35
115	21	415	92	17	37
120	22	433	96	17	39
125	23	451	100	18	40
130	24	469	104	19	42
135	25	487	108	20	43
140	25	505	112	20	45
145	26	523	116	21	47
150	27	541	120	22	48
155	28	559	124	23	50
160	29	577	128	23	51
165	30	595	132	24	53
170	31	613	136	25	55
175	32	631	140	25	56
180	33	649	144	26	58
185	34	667	148	27	59

Specific Gravity (SG): 1.26

Please note that the SG varies slightly with temperature

Apply with appropriate nozzles

Avoid application during very windy weather or when the leaf is damp

Do not apply on a rime frost or following severe frost

Application Chart Nitroflo 20+S: 20%N + 5%S

kg/ha N	METRIC			IMPERIAL	
	kg/ha S	l/ha	units/ac N	units/ac S	galls/ac
25	6	100	20	5	9
30	8	120	24	6	11
35	9	140	28	7	12
40	10	160	32	8	14
45	11	180	36	9	16
50	13	200	40	10	18
55	14	220	44	11	20
60	15	240	48	12	21
65	16	260	52	13	23
70	18	280	56	14	25
75	19	300	60	15	27
80	20	320	64	16	28
85	21	340	68	17	30
90	23	360	72	18	32
95	24	380	76	19	34
100	25	400	80	20	36
105	26	420	84	21	37
110	28	440	88	22	39
115	29	460	92	23	41
120	30	480	96	24	43
125	31	500	100	25	45
130	33	520	104	26	46
135	34	540	108	27	48
140	35	560	112	28	50
145	36	580	116	29	52
150	38	600	120	30	53
155	39	620	124	31	55
160	40	640	128	32	57
165	41	660	132	33	59
170	43	680	136	34	61
175	44	700	140	35	62
180	45	720	144	36	64
185	46	740	148	37	66

Specific Gravity (SG): 1.25

Please note that the SG varies slightly with temperature

Apply with appropriate nozzles

Avoid application during very windy weather or when the leaf is damp

Do not apply on a rime frost or following severe frost

Application Charts - Solution Compound Fertilisers - Metric

OMEX 16-0-7			
kg/ha N	kg/ha P	kg/ha K	l/ha
10	0	4	54
20	0	8	108
30	0	13	162
40	0	17	216
50	0	21	269
60	0	25	323
70	0	29	377
80	0	33	431
90	0	38	485
100	0	42	539
110	0	46	593
120	0	50	647
130	0	54	700
140	0	58	753
150	0	63	808
160	0	67	862
170	0	71	916
180	0	75	970
190	0	79	1024
200	0	83	1078
Specific Gravity (SG): 1.16			
UK Analysis 16-0-8			

OMEX 15-1.5-6			
kg/ha N	kg/ha P	kg/ha K	l/ha
10	1	4	56
20	2	8	111
30	3	13	167
40	4	17	222
50	5	21	278
60	6	25	333
70	7	29	389
80	8	33	444
90	9	38	500
100	10	42	556
110	11	46	611
120	12	50	667
130	13	54	722
140	14	58	778
150	15	63	833
160	16	67	889
170	17	71	944
180	18	75	1000
190	19	79	1056
200	20	83	1111
Specific Gravity (SG): 1.20			
UK Analysis 15-3.5-7.5			

OMEX 14-3-6			
kg/ha N	kg/ha P	kg/ha K	l/ha
10	2	4	58
20	4	8	115
30	7	12	173
40	9	17	230
50	11	21	288
60	13	25	346
70	15	29	403
80	17	33	461
90	20	37	518
100	22	42	576
110	24	46	634
120	26	50	691
130	28	54	749
140	30	58	806
150	33	62	864
160	35	67	922
170	37	71	979
180	39	75	1037
190	41	79	1094
200	43	83	1152
Specific Gravity (SG): 1.24			
UK Analysis 14-7-7			

OMEX 10-2-7.5			
kg/ha N	kg/ha P	kg/ha K	l/ha
10	5	9	83
20	10	18	167
30	15	27	250
40	20	36	333
50	25	45	417
60	30	54	500
70	35	63	583
80	40	72	667
90	45	81	750
100	50	90	833
110	55	99	917
120	60	108	1000
130	65	117	1083
140	70	126	1167
150	75	135	1250
160	80	144	1333
170	85	153	1417
180	90	162	1500
190	95	171	1583
200	100	180	1667
Specific Gravity (SG): 1.20			
UK Analysis 10-5-9			

OMEX 10-0-8			
kg/ha N	kg/ha P	kg/ha K	l/ha
10	0	8	83
20	0	17	167
30	0	25	250
40	0	33	333
50	0	42	417
60	0	50	500
70	0	58	583
80	0	67	667
90	0	75	750
100	0	83	833
110	0	92	917
120	0	100	1000
130	0	108	1083
140	0	117	1167
150	0	125	1250
160	0	133	1333
170	0	142	1417
180	0	150	1500
190	0	158	1583
200	0	167	1667
Specific Gravity (SG): 1.20			
UK Analysis 10-0-10			

OMEX 9-4-7.5			
kg/ha N	kg/ha P	kg/ha K	l/ha
10	4	8	89
20	9	17	178
30	13	25	267
40	17	33	356
50	22	42	444
60	26	50	533
70	30	58	622
80	35	67	711
90	39	75	800
100	43	83	889
110	48	92	978
120	52	100	1067
130	57	108	1156
140	61	117	1244
150	65	125	1333
160	70	133	1422
170	74	142	1511
180	78	150	1600
190	83	158	1689
200	87	167	1778
Specific Gravity (SG): 1.25			
UK Analysis 9-9-9			

Conversion factors - P: P₂O₅ divide by 0.44
K: K₂O divide by 0.83

Application Charts - Solution Compound Fertilisers - Metric

OMEX 9-1-8			
kg/ha N	kg/ha P	kg/ha K	l/ha
10	3	11	93
20	7	22	187
30	10	33	280
40	13	44	373
50	17	56	467
60	20	67	560
70	23	78	654
80	27	89	747
90	30	100	840
100	33	111	934
110	37	122	1027
120	40	133	1120
130	43	144	1214
140	47	156	1307
150	50	167	1401
160	53	178	1494
170	57	189	1587
180	60	200	1681
190	63	211	1774
200	67	222	1867
Specific Gravity (SG): 1.19			
UK Analysis 9-3-10			

OMEX 7-9-0		
kg/ha N	kg/ha P	l/ha
4	5	47
8	10	94
12	15	141
16	20	189
20	25	236
24	30	283
28	35	330
32	40	377
36	45	424
40	50	471
44	55	518
48	60	566
52	65	613
56	70	660
60	75	707
64	80	754
68	85	801
72	90	848
76	95	895
80	100	943
Specific Gravity (SG): 1.22		
UK Analysis 7-20-0		

OMEX 7-3-8			
kg/ha N	kg/ha P	kg/ha K	l/ha
10	4	12	115
20	9	24	230
30	13	36	346
40	17	48	461
50	22	60	576
60	26	71	691
70	30	83	806
80	35	95	922
90	39	107	1037
100	43	119	1152
110	48	131	1267
120	52	143	1382
130	57	155	1498
140	61	167	1613
150	65	179	1728
160	70	190	1843
170	74	202	1959
180	78	214	2074
190	83	226	2189
200	87	238	2304
Specific Gravity (SG): 1.24			
UK Analysis 7-7-10			

OMEX 3.5-4.5-8			
kg/ha N	kg/ha P	kg/ha K	l/ha
4	5	10	93
8	10	19	186
12	15	29	278
16	20	38	371
20	25	48	464
24	30	57	557
28	35	67	649
32	40	77	742
36	45	86	835
40	50	96	928
44	55	105	1020
48	60	115	1113
52	65	125	1206
56	70	134	1299
60	75	144	1391
64	80	153	1484
68	85	163	1577
72	90	172	1670
76	95	182	1763
80	100	192	1855
Specific Gravity (SG): 1.24			
UK Analysis 3.5-10-10			

OMEX 14-6-0		
kg/ha N	kg/ha P	l/ha
5	2	30
10	4	59
15	7	89
20	9	118
25	11	148
30	13	177
35	15	207
40	17	236
45	20	266
50	22	295
55	24	325
60	26	354
65	28	384
70	30	413
75	33	443
80	35	472
85	37	502
90	39	531
95	41	561
100	43	590
Specific Gravity (SG): 1.21		
UK Analysis 14-14-0		

OMEX 17-3.5-0		
kg/ha N	kg/ha P	l/ha
5	1	25
10	2	49
15	3	74
20	4	98
25	5	123
30	6	147
35	7	172
40	8	196
45	9	221
50	10	245
55	11	270
60	12	294
65	13	319
70	14	343
75	15	368
80	16	392
85	17	417
90	18	441
95	19	466
100	20	490
Specific Gravity (SG): 1.20		
UK Analysis 17-8-0		

Conversion factors - P₂O₅: P multiplied by 0.44
 k₂O: K multiplied by 0.83

Application Charts - Solution Compound Fertilisers - Imperial

OMEX 16-0-7				
u/ac N	u/ac P	u/ac K	galls/ac	l/ha
10	0	4	6	67
20	0	8	12	135
30	0	13	18	202
40	0	17	24	269
50	0	21	30	337
60	0	25	36	404
70	0	29	42	471
80	0	33	48	539
90	0	38	54	606
100	0	42	60	673
110	0	46	66	741
120	0	50	72	808
130	0	54	78	876
140	0	58	84	943
150	0	63	90	1010
160	0	67	96	1078
170	0	71	102	1145
180	0	75	108	1212
190	0	79	114	1280
200	0	83	120	1347
Specific Gravity (SG): 1.16				
UK Analysis 16-0-8				

OMEX 15-1.5-6				
u/ac N	u/ac P	u/ac K	galls/ac	l/ha
10	1	4	6	69
20	2	8	12	139
30	3	13	19	208
40	4	17	25	278
50	5	21	31	347
60	6	25	37	417
70	7	29	43	486
80	8	33	49	556
90	9	38	56	625
100	10	42	62	694
110	11	46	68	761
120	12	50	74	833
130	13	54	80	903
140	14	58	87	972
150	15	63	93	1042
160	16	67	99	1111
170	17	71	105	1181
180	18	75	111	1250
190	19	79	117	1319
200	20	83	124	1389
Specific Gravity (SG): 1.20				
UK Analysis 15-3.5-7.5				

OMEX 14-3-6				
u/ac N	u/ac P	u/ac K	galls/ac	l/ha
10	2	4	6	72
20	4	8	13	144
30	7	12	19	216
40	9	17	26	288
50	11	21	32	360
60	13	25	38	432
70	15	29	45	504
80	17	33	51	576
90	20	37	58	648
100	22	42	64	720
110	24	46	71	792
120	26	50	77	864
130	28	54	83	936
140	30	58	90	1008
150	33	62	96	1080
160	35	67	103	1152
170	37	71	109	1224
180	39	75	115	1296
190	41	79	122	1368
200	43	83	128	1440
Specific Gravity (SG): 1.24				
UK Analysis 14-7-7				

OMEX 10-2-7.5				
u/ac N	u/ac P	u/ac K	galls/ac	l/ha
10	2	8	9	104
20	4	15	19	208
30	7	23	28	313
40	9	30	37	417
50	11	38	46	521
60	13	45	56	625
70	15	53	65	729
80	17	60	74	833
90	20	68	83	938
100	22	75	93	1042
110	24	83	102	1146
120	26	90	111	1250
130	28	98	121	1354
140	30	105	130	1458
150	33	113	139	1563
160	35	120	148	1667
170	37	128	158	1771
180	39	135	167	1875
190	41	143	176	1979
200	43	150	185	2083
Specific Gravity (SG): 1.20				
UK Analysis 10-5-9				

OMEX 10-0-8				
u/ac N	u/ac P	u/ac K	galls/ac	l/ha
10	0	8	9	104
20	0	17	19	208
30	0	25	28	313
40	0	33	37	417
50	0	42	46	521
60	0	50	56	625
70	0	58	65	729
80	0	67	74	833
90	0	75	83	938
100	0	83	93	1042
110	0	92	102	1146
120	0	100	111	1250
130	0	108	121	1354
140	0	117	130	1458
150	0	125	139	1563
160	0	133	148	1667
170	0	142	158	1771
180	0	150	167	1875
190	0	158	176	1979
200	0	167	185	2083
Specific Gravity (SG): 1.20				
UK Analysis 10-0-10				

OMEX 9-4-7.5				
u/ac N	u/ac P	u/ac K	galls/ac	l/ha
10	4	8	10	111
20	9	17	20	222
30	13	25	30	333
40	17	33	40	444
50	22	42	49	556
60	26	50	59	667
70	30	58	69	778
80	35	67	79	889
90	39	75	89	1000
100	43	83	99	1111
110	48	92	109	1222
120	52	100	119	1333
130	57	108	129	1444
140	61	117	138	1556
150	65	125	148	1667
160	70	133	158	1778
170	74	142	168	1889
180	78	150	178	2000
190	83	158	188	2111
200	87	167	198	2222
Specific Gravity (SG): 1.25				
UK Analysis 9-9-9				

Conversion factors - P: P₂O₅ divide by 0.44
K: K₂O divide by 0.83

Application Charts - Solution Compound Fertilisers - Imperial

OMEX 9-1-8				
u/ac N	u/ac P	u/ac K	galls/ac	l/Ha
10	1	9	10	117
20	3	19	21	233
30	4	28	31	350
40	6	37	42	467
50	7	46	52	584
60	9	56	62	700
70	10	65	73	817
80	12	74	83	934
90	13	83	94	1050
100	14	93	104	1167
110	16	102	114	1284
120	17	111	125	1401
130	19	120	135	1517
140	20	130	145	1634
150	22	139	156	1751
160	23	148	166	1867
170	25	157	177	1984
180	26	167	187	2101
190	27	176	197	2218
200	29	185	208	2334
Specific Gravity (SG): 1.19				
UK Analysis 9-3-10				

OMEX 7-9-0			
u/ac N	u/ac P	galls/ac	l/Ha
4	5	5	59
8	10	10	118
12	15	16	177
16	20	21	236
20	25	26	295
24	30	31	353
28	35	37	412
32	40	42	471
36	45	47	530
40	50	52	589
44	55	58	648
48	60	63	707
52	65	68	766
56	70	73	825
60	75	79	884
64	80	84	943
68	85	89	1001
72	90	94	1060
76	95	100	1119
80	100	105	1178
Specific Gravity (SG): 1.22			
UK Analysis 7-20-0			

OMEX 7-3-8				
u/ac N	u/ac P	u/ac K	galls/ac	l/Ha
10	4	12	13	144
20	9	24	26	288
30	13	36	38	432
40	17	48	51	576
50	22	60	64	720
60	26	71	77	864
70	30	83	90	1008
80	35	95	103	1152
90	39	107	115	1296
100	43	119	128	1440
110	48	131	141	1584
120	52	143	154	1728
130	57	155	167	1872
140	61	167	179	2016
150	65	179	192	2160
160	70	190	205	2304
170	74	202	218	2448
180	78	214	231	2592
190	83	226	244	2736
200	87	238	256	2880
Specific Gravity (SG): 1.24				
UK Analysis 7-7-10				

OMEX 3.5-4.5-8				
u/ac N	u/ac P	u/ac K	galls/ac	l/Ha
4	5	10	10	115
8	10	19	21	230
12	15	29	31	346
16	20	38	41	461
20	25	48	52	576
24	30	57	62	691
28	35	67	72	806
32	40	77	83	922
36	45	86	93	1037
40	50	96	103	1152
44	55	105	114	1267
48	60	115	124	1382
52	65	125	134	1498
56	70	134	145	1613
60	75	144	155	1728
64	80	153	165	1843
68	85	163	175	1959
72	90	172	186	2074
76	95	182	196	2189
80	100	192	206	2304
Specific Gravity (SG): 1.24				
UK Analysis 3.5-10-10				

OMEX 14-6-0			
u/ac N	u/ac P	galls/ac	l/Ha
5	2	3	37
10	4	7	74
15	7	10	111
20	9	13	148
25	11	16	184
30	13	20	221
35	15	23	258
40	17	26	295
45	20	30	332
50	22	33	369
55	24	36	406
60	26	39	443
65	28	43	480
70	30	46	517
75	33	49	553
80	35	53	590
85	37	56	627
90	39	59	664
95	41	62	701
100	43	66	738
Specific Gravity (SG): 1.21			
UK Analysis 14-14-0			

OMEX 17-3.5-0			
u/ac N	u/ac P	galls/ac	l/Ha
5	1	3	31
10	2	5	61
15	3	8	92
20	4	11	123
25	5	14	153
30	6	16	184
35	7	19	214
40	8	22	245
45	9	25	276
50	10	27	306
55	11	30	337
60	12	33	368
65	13	35	398
70	14	38	429
75	15	41	460
80	16	44	490
85	17	46	521
90	18	49	551
95	19	52	582
100	20	55	613
Specific Gravity (SG): 1.20			
UK Analysis 17-8-0			

Conversion factors - P₂O₅: P multiplied by 0.44
K₂O: K multiplied by 0.83

Other Solution Compound Fertiliser Analyses also available

Analysis - % w/w				Analysis - % w/v		
N	P	K	SG	N	P	K
16	0	3	1.14	18	0	4
15	1.5	3	1.18	18	2	3.5
12.5	2	7	1.20	15	2	8.5
12	2	4	1.18	14	2	4
11.5	3.5	7	1.24	14	4	8
11.5	1.5	7.5	1.20	14	2	9
11	1.5	4	1.18	13	2	5
10.5	3	7	1.24	13	4	9
10	15	0	1.38	14	20	0
9	1	5	1.17	10.5	1.5	6
8.5	2	4	1.18	10	2.5	5
8	3.5	8	1.24	10	4	10
6.5	4	8	1.24	8	5	10
6	3	8	1.23	7.5	3.5	10
5.5	3	9	1.24	6.5	4	11
5	3.5	8	1.24	6	4.5	10
4.5	3	9	1.23	5.5	3	11
3	3.5	9	1.23	3.5	4	11
2	2.5	10	1.23	2.5	3	12

OMEX solution compounds are also available with S, up to a maximum inclusion of 2 S. Inclusion of S can change the final grade of the product, for example:

A 15-1.5-6 becomes 15-1.4-5.5+2S

w/v analyses are approximate

Quick Guide to Converting To Nitroflo Liquid N

To convert to Nitroflo liquid N is simple and not expensive.

Application:

- You will need to buy a set of nozzles designed to apply liquid N. Remember, the target is the soil, not the crop. (See pages 30-33)
- Check with your sprayer dealer that your sprayer is set up to apply liquid fertiliser. (Most sprayers built in the last 10-15 years are)
- Alternatively, there is now a good network of contractors who can apply liquid N; contact your local OMEX distributor.

Storage:

- If you just want to try the product, storage is not needed, all the distributors in Ireland will supply small quantities in IBCs.
- Once you have decided you want your own storage facility, you can rent a storage tank from OMEX (see pages 34-36). You will need to build a concrete base and bund. OMEX will help advise where and how best to do this.

Buying Nitroflo:

- You can buy IBCs of Nitroflo from your OMEX distributor at any time during the season.

- You can buy bulk loads either pre-season or in-season.

Delivery:

- IBCs are delivered within a couple of days by the distributor.
- Bulk loads arrive directly from OMEX. Delivery is usually 4-5 days in-season, but can be done more quickly if urgent.
- Bulk loads should be discharged into fertiliser tanks positioned inside a bund.
- In season, bulk loads can be discharged into temporary storage containers provided environmental safety conditions are met and there is someone available to help.
- Road tankers can be filled provided there is a tractor unit or bogey carrying the pin. Bowsers can be filled provided they are firmly attached to the trailer or running gear; both must be positioned on level hard standing and the vessel suitable for bottom filling.
- Bulk loads can be discharged into IBCs if this is arranged at time of order

Frequently Asked Questions and Comments

Q "Isn't liquid fertiliser often associated with scorch?"

A Current application methods have virtually eliminated scorch and by following a few simple guidelines, scorch is not a problem

Q "Surely liquid nitrogen is too expensive?"

A The price of OMEX liquid nitrogen has for many years been competitive against UK produced ammonium nitrate

Q "Liquid nitrogen is corrosive."

A All nitrogen fertilisers can be mildly corrosive to unprotected steel. By cleaning down a sprayer after applying fertiliser, the sprayer condition will deteriorate no more than if it was used for conventional spraying alone

Q "There is a risk of urea volatilising in warm weather."

A The Nitroflo range contains liquid urea which rapidly enters the soil and is stabilised, reducing the risk of ammonia losses compared to solid urea

Q "Isn't it expensive to convert to liquid?"

A The cost of converting should be as little as the cost of a bunded concrete plinth for a storage tank and a set of nozzles. The storage site will be assessed by OMEX, the cost of bunding over the life of the site is low and the cost of storage tank is subsidised by OMEX.

Application Bars & Nozzles

A range of streamer caps and streamer bars are available for applying liquid nitrogen to emerged crops. They vary from simple caps to advanced, self-contained streamer bars. Check with suppliers for latest prices

Spraying Systems (TeeJet) Jet Stream

A simple cap producing 3 divergent vertical streams. Rate is altered by varying pressure and metering disc.

Lechler FD Fertiliser Nozzle

A novel, low pressure deflector nozzle, producing a horizontal fan pattern of coarse droplets with no 'fines'. Even distribution (no streams) and flexible application rates (operate at pressure of 2-4 bar).

Spraying Systems (TeeJet) Stream Jet SJ7

A 7-stream jet which produces a 'rain-effect' pattern across the boom. A recent change is that the jet body is now integral with metering disc, so different coloured bodies are used for different rates; no need to change metering discs. (See page 32)

Hypro Fastcap® ESI

6-stream cap, with streams directed down onto crop, claimed to produce a low-atomisation stream of nitrogen. Supplied as nozzle+metering orifice with two nozzles required to cover most application rates. Supplied in a box of 6 nozzles.

Hardi Quintastream

Produce 5 semi-vertical streams, each stream engineered to create an accurate and even application on the crop. They come with Hardi jet bodies but can be adapted to Teejet bodies by removing the nozzle insert from the body and mounting in a Teejet cap. Rate altered by changing restrictor with tool that comes with jet. Different coloured bodies for different rates.

Umbrella Jets

Produce a 'rain-effect' of low pressure, large droplets from a semi-circle of outlets at the base of an extended nozzle body giving a wide range of application rates simply by varying pressure.

CFM Streamer Bar

A channel-fed bar, with 4 vertical streams per bar. Rate is altered by varying pressure and selecting restrictor that is simple to change.

BFS Streamer Bar

A channel-fed bar, with 4 vertical streams from each ½m spacing bar. Application rate is altered by varying pressure and rotating a wheel in the body of the bar to required metering orifice.

OMEX Streambar

The OMEX Streambar produces 4 vertical streams from each bar, ensuring even coverage across the full boom regardless of the bars height above the ground. Each stream is fed individually to ensure the output from all four streams are identical even with the bar tilted. A wide range of application rates can be achieved and are changed using the built in slider. (see page 31)

Spraying Systems (TeeJet) SJ7-VR

A half umbrella pattern with 7 streams and a variable rate restrictor for use with flow-based controllers. Restrictor is based on reliable EPDM elastomer and allows rate to vary with speed or variable rate map, without the need to change jets.

Spraying Systems (TeeJet) SJ3-VR

Three divergent streams with a variable rate restrictor, only for use with flow based controllers. No need to change metering discs or settings and restrictor provides constant resistance to allow rates to be changed on the move.

Pentair (Hypro) ESI variable rate nozzle

Variable restrictor based on integral variable orifice. Produces 6 divergent streams from novel unique nozzle body. Correct pattern overlap at 3 boom heights provides flexibility. Single nozzle covers wide range of application rates and allows rate to be changed in operation, ideal for variable rate application.

AccuRate Dribblebar

Precision rate control with stainless steel regulator. Applies for 90-2200 l/ha with minimal setting. Minimal drip when switched off. Ideal for use on second spray line.

Please check with suppliers for latest prices

OMEX Steambar



Streamer bars are the most efficient and accurate method of applying nitrogen to crops and the OMEX Steambar is one of the most convenient and cost-effective bars available.

Streambars apply liquid nitrogen and sulphur in a vertical stream, allowing nitrogen to be applied at the full rate right up to the field boundary. The vertical spray pattern means boom height is not restricted, allowing booms to run low in windy

conditions and ensuring that the pattern is not affected by undulating ground. Each of the four outlets on the bar is fed independently from the restrictor, so the rate remains completely consistent across the bar on sloping ground.



Quality Design

The OMEX Steambar is manufactured in the UK and the compact design reduces the risk of breakage if the boom makes contact with the crop, ground or hedges. The bars have linking hooks to allow them to be connected if required, to prevent them twisting out of line. The bars are fully serviceable with three O-ring seals being the only wearing parts.

Droplet Size

The stream produced by the bar breaks into individual, large droplets soon after leaving the bar and the large heavy droplets are key to reducing the risk of scorch.

Application Tables

Application rates are conveniently altered with a sliding restrictor, allowing a full wide range of application rates to be achieved without changing nozzle bodies or restrictors and keeping the operator clean and free of contact with fertiliser.

Simple to use application charts are supplied with the Streambars, detailing either the litres/hectare or kg/ha nitrogen applied - removing the need for a separate product application chart. As an office-based support, a simple calculator is also available to run on a PC.



STREAMJET® SJ7 FERTILIZER NOZZLE

Advanced spraying of liquid fertilizer with the StreamJet SJ-7, seven orifice nozzle; successor to the TeeJet 8-orifice cap.



Features and Benefits

- Seven precise solid streams form extremely large drops with minimal impact power
- Excellent distribution via semi-circular spray pattern – with corresponding overlap
- New wider range of sizes (-015 to -15) give a significantly greater application volume choice, especially for nitrogen-based fertilizers
- ISO-colour coding (VisiFlo®) for easy selection of nozzle size
- Integrated, color-coded removable pre-orifice
- Overall length is the same as the AI TeeJet; 15° angled spray off the horizontal provide a practical way to spray under boom struts
- Operating pressures from 1,5 to 4 bar;
Spray height 75 – 100 cm
- Made of Acetal for high chemical resistance
- Extension of 27 mm possible with 50854-NYB Adapter

Colour coded capacity orifice

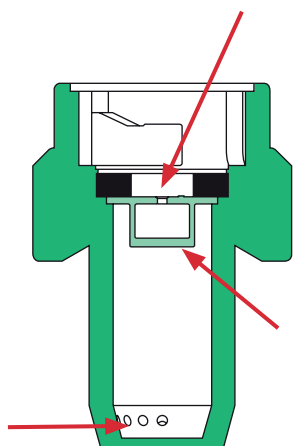

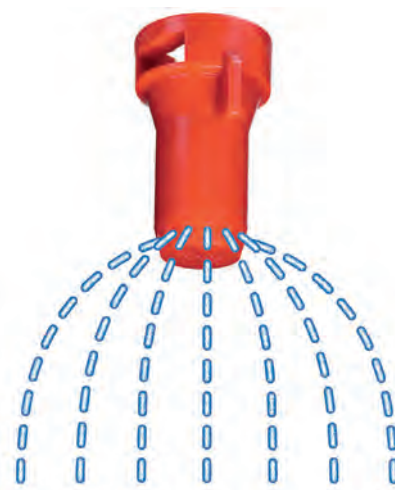

Distribution plate

Outlet orifices

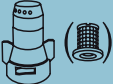

APPLICATION INFORMATION

	 Bar	WATER CAPACITY (L/MIN)	FERTILIZER CAPACITY (L/MIN)	HEIGHT (CM)	APPLICATION RATE (L/HA) FOR LIQUID DENSITY OF 1,28 KG/L												
					6 km/h	7 km/h	8 km/h	9 km/h	10 km/h	11 km/h	12 km/h	13 km/h	14 km/h	15 km/h	16 km/h	18 km/h	20 km/h
SJ7-015VP	1.5	0.39	0.35	75-100	69	59	52	46	41	38	35	32	30	28	26	23	21
	2.0	0.46	0.41		81	70	61	54	49	44	41	38	35	33	31	27	24
	2.5	0.52	0.46		92	79	69	61	55	50	46	42	39	37	35	31	28
	3.0	0.57	0.50		101	86	76	67	61	55	50	47	43	40	38	34	30
	3.5	0.63	0.56		112	96	84	75	67	61	56	52	48	45	42	37	34
4.0	0.67	0.59	119	102	89	79	71	65	59	55	51	47	44	40	36		
SJ7-02VP	1.5	0.55	0.49	75-100	97	83	73	65	58	53	49	45	42	39	37	32	29
	2.0	0.64	0.57		113	97	85	76	68	62	57	52	49	45	42	38	34
	2.5	0.72	0.64		127	109	96	85	76	70	64	59	55	51	48	42	38
	3.0	0.80	0.71		142	121	106	94	85	77	71	65	61	57	53	47	42
	4.0	0.86	0.75		150	129	113	100	90	82	75	69	64	60	56	50	45
4.0	0.93	0.82	165	141	123	110	99	90	82	76	71	66	62	55	49		
SJ7-03VP	1.5	0.87	0.77	75-100	154	132	115	103	92	84	77	71	66	62	58	51	46
	2.0	1.00	0.88		177	152	133	118	106	97	88	82	76	71	66	59	53
	2.5	1.10	0.97		195	167	146	130	117	106	97	90	83	78	73	65	58
	3.0	1.18	1.04		209	179	157	139	125	114	104	96	90	84	78	70	63
	3.5	1.27	1.12		224	192	168	149	134	122	112	103	96	90	84	75	67
4.0	1.31	1.16	232	199	174	155	139	126	116	107	99	93	87	77	70		
SJ7-04VP	1.5	1.17	1.04	75-100	207	177	155	138	124	113	104	96	89	83	78	69	62
	2.0	1.33	1.18		235	202	177	157	141	128	118	109	101	94	88	78	71
	2.5	1.45	1.28		257	220	192	171	154	140	128	118	110	103	96	86	77
	3.0	1.55	1.37		274	235	206	183	165	150	137	127	118	110	103	91	82
	3.5	1.66	1.47		294	252	220	196	176	160	147	136	126	118	110	98	88
4.0	1.72	1.52	304	261	228	203	183	166	152	141	130	122	114	101	91		
SJ7-05VP	1.5	1.49	1.32	75-100	264	226	198	176	158	144	132	122	113	105	99	88	79
	2.0	1.68	1.49		297	255	223	198	178	162	149	137	127	119	112	99	89
	2.5	1.83	1.62		324	278	243	216	194	177	162	149	139	130	121	108	97
	3.0	1.95	1.73		345	296	259	230	207	188	173	159	148	138	129	115	104
	3.5	2.11	1.87		374	321	281	249	224	204	187	173	160	150	140	125	112
4.0	2.16	1.91	382	328	287	255	229	209	191	176	164	153	143	127	115		
SJ7-06VP	1.5	1.77	1.57	75-100	313	269	235	209	188	171	157	145	134	125	117	104	94
	2.0	2.01	1.78		356	305	267	237	213	194	178	164	152	142	133	119	107
	2.5	2.19	1.94		388	332	291	258	233	211	194	179	166	155	145	129	116
	3.0	2.35	2.08		416	357	312	277	250	227	208	192	178	166	156	139	125
	4.0	2.61	2.31		462	396	346	308	277	252	231	213	198	185	173	154	139
SJ7-08VP	1.5	2.28	2.02	75-100	404	346	303	269	242	220	202	186	173	161	151	135	121
	2.0	2.66	2.35		471	404	353	314	282	257	235	217	202	188	177	157	141
	2.5	2.94	2.60		520	446	390	347	312	284	260	240	223	208	195	173	156
	3.0	3.15	2.79		558	478	418	372	335	304	279	257	239	223	209	186	167
	4.0	3.46	3.06		612	525	459	408	367	334	306	283	262	245	230	204	184
SJ7-10VP	1.5	2.84	2.51	75-100	503	431	377	335	302	274	251	232	215	201	188	168	151
	2.0	3.32	2.94		588	504	441	392	353	321	294	271	252	235	220	196	176
	2.5	3.67	3.25		650	557	487	433	390	354	325	300	278	260	244	217	195
	3.0	3.94	3.49		697	598	523	465	418	380	349	322	299	279	262	232	209
	4.0	4.33	3.83		766	657	575	511	460	418	383	354	328	307	287	255	230
SJ7-15VP	1.5	4.09	3.62	75-100	724	620	543	483	434	395	362	334	310	290	271	241	217
	2.0	4.82	4.27		853	731	640	569	512	465	427	394	366	341	320	284	256
	2.5	5.40	4.78		956	819	717	637	573	521	478	441	410	382	358	319	287
	3.0	5.87	5.19		1039	891	779	693	623	567	519	480	445	416	390	346	312
	4.0	6.58	5.82		1165	998	873	776	699	635	582	538	499	466	437	388	349

Note : Always double check your application rates. Tabulations are based on spraying a liquid with density of 1.28 kg/l at 21° C.

OPTIMUM SPRAY HEIGHT

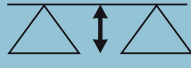
	
50 cm	50 cm
75 cm	75 cm
100 cm	100 cm

Storage Tank Schemes

Rental Scheme for 30m³, 40m³ and 50m³ GRP Tanks

	30m ³	40m ³	50m ³
Farmer Qualification			
New customer to OMEX Nitroflo		Yes	
Minimum number of tonnes of Nitroflo per annum	50	100	120
OMEX to Supply			
One tank, complete with fully lockable filling valve, inspection and cleaning access hatch, sight gauge on steel tanks, GRP fixing ties and locks.	30,000 litre (approx 37 tonne capacity)	40,000 litre (approx 50 tonne capacity)	50,000 litre (approx 60 tonne capacity)
Tank delivered and off loaded on farm		Yes	
Drawings showing dimensions of tank plus foundations if required		Yes	
The Scheme			
Year one free of charge		Yes	
An annual rental (payable in advance)	€500	€700	€800
A retrospective rebate of €4.00 per tonne will be paid per annum on Nitroflo range only	Up to the value of €500	Up to the value of €700	Up to the value of €800
Farmer to Supply			
An accessible site for tank		Yes	
Concrete foundation and bund for tank		Yes	
Roofing felt layer beneath tank		Yes	
Bolts and fixing		Yes	
Planning permission (if required)		Yes	

All prices exclude VAT



OMEX Agriculture reserves the right to uplift the tank if annual offtake falls below 50 tonnes for the 30m³ and 40m³, and 100 tonnes for the 50m³ tank or if rental is unpaid. The farmer is responsible for paying crane hire for the removal of the tank.

Purchase option for 30m³, 40m³ and 50m³ GRP Tanks

	30m ³	40m ³	50m ³
Purchase Cost			
GRP tank (ex delivery)	€5,000	€7,000	€8,000
Included			
One GRP tank, complete with fully lockable filling valve, inspection and cleaning access hatch, fixing ties and locks	30,000 litre (approx 37 tonne capacity)	40,000 litre (approx 50 tonne capacity)	50,000 litre (approx 60 tonne capacity)
Tank delivered (charges apply) and off loaded on farm	Yes		
Drawings showing dimensions of tank plus foundations if required	Yes		
The Scheme			
Farmer to purchase tanks from OMEX	Yes		
A retrospective rebate of €4.00 per tonne against OMEX Nitroflo products only	Yes		
To be paid annually, for 10 years maximum	Yes		
Cumulative rebate up to the purchase price of the tank	Yes		
Tank maintenance and security is purchaser's responsibility	Yes		
Farmer to Supply			
An accessible site for tank	Yes		
Concrete foundation and bund for tank	Yes		
Roofing felt layer beneath tank	Yes		
Bolts and fixing are customers responsibility	Yes		
Planning permission (if required)	Yes		

All prices exclude VAT

Please contact your OMEX sales contact.



Tank Base & Bund Dimensions

For 30m³ GRP Tank

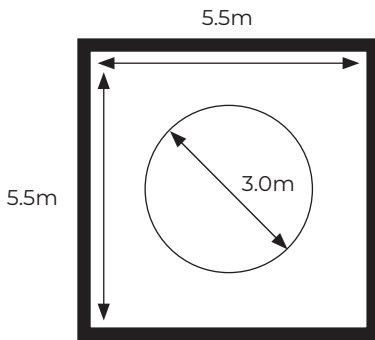

Example, 1.1m high

Tank Height: 4.65m

Min Bund Capacity	1 Tank	2 Tanks	3 Tanks
	33m ³	42m ³	50m ³

Examples of dimensions

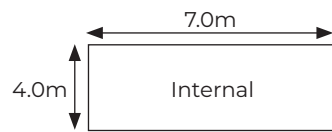

1.2m high

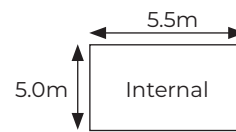

1.2m high

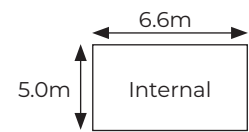

1.0m high

For 40m³ GRP Tank

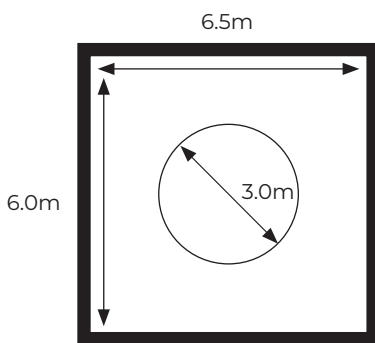

Example, 1.2m high

Tank Height: 6.02m

Min Bund Capacity	1 Tank	2 Tanks	3 Tanks
	44m ³	53m ³	61m ³

Examples of dimensions

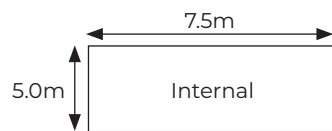

1.2m high

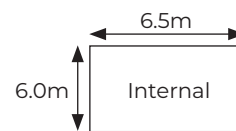

1.2m high

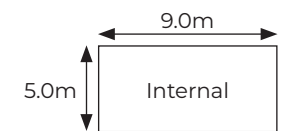

1.0m high

For 50m³ GRP Tank

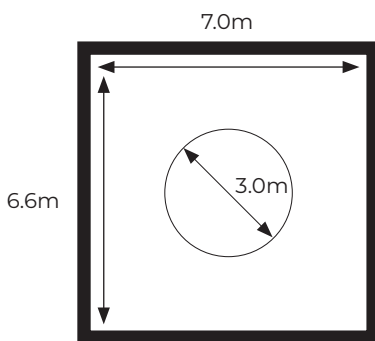

Example, 1.2m high

Tank Height: 7.4m

Min Bund Capacity	1 Tank	2 Tanks	3 Tanks
	55m ³	64m ³	72m ³

Examples of dimensions

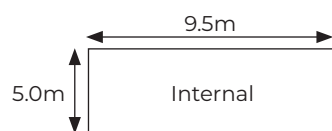

1.2m high

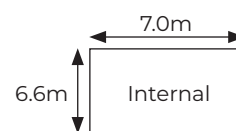

1.2m high

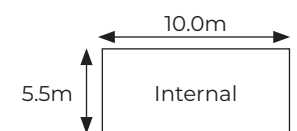

1.0m high

Tank Base



- The thickness will depend on the ground conditions
- It should be a flat, smooth reinforced concrete slab
- Minimum 200mm thick

Illustrations above are for basic calculations, specific sites and bund specifications to be agreed and finalised with an on farm assessment from an OMEX representative.

PROTECTING THE ENVIRONMENT

THE ESSENTIALS FOR STORING SOLID AND LIQUID FERTILISERS



Losses from stored fertiliser may:

- seriously damage water quality
- lead to substantial fines for pollution

Today, farm storage of fertilisers is covered by Codes of Practice to prevent water pollution. Unless farmers adhere to these codes, enforcement action could be taken or new legislation imposed.⁽¹⁾ This leaflet summaries your obligations under the Codes.

Adhering to the codes is not daunting. Often a little time spent on inspection, planning and a small investment in maintenance will avoid large fines, upset neighbours and loss of reputation.

Footnote

1. The Anti-Pollution Works Regulations 1999, www.legislation.gov.uk or from The Stationery Office, T: 0870 6005522
2. Code of Practice for the Prevention of Water Pollution from the Storage and Handling of Fluid and Solid Fertilisers – free from Agricultural Industries Confederation, T: 01733 385230 or from website www.agindustries.org.uk
3. The Dangerous Substances (Notification and Marking of Sites) Regulations 1990, www.legislation.gov.uk, The Stationery Office, T: 0870 6005522

GENERAL GUIDELINES FOR ALL STORES

- Site all stores as far from watercourses or surface water drains as possible – never less than 10m.
- Site at least 50m from any well, borehole, or aquifer outcrop where risk of groundwater contamination is high.
- Provide secondary containment for storage where contamination risk is high.
- Ensure good well constructed vehicular access.
- Keep an inventory of fertiliser stored – type, volume, delivery.
- Make all storage as secure as possible with consideration given to lighting and fencing.
- Site all stores away from public access to minimise interference or vandalism.
- Ensure operators are trained in use and emergency procedures.
- Obtain Code of Practice for the Prevention of Water Pollution from the Storage and Handling of Fluid and Solid Fertilisers⁽²⁾ – the definitive reference.

SOLID FERTILISER STORAGE

Solid fertilisers, provided the storage area is well-sited and constructed, are a low risk of watercourses. The main risk occurs in the event of a fire, if contaminated firewater escapes.

PERMANENT STORES

Siting

- Locate away from heat sources to minimise fire risk.
- Site away from combustible materials eg fuels, oils, hay, straw and wood.
- Ensure sites are level and not prone to flooding.
- Ensure indoor storage is on smooth, firm, dry, impermeable concrete floors.
- Avoid prolonged outdoor storage but where unavoidable ensure it is protected from rain and sunlight with shrink wrapping and/or sheeting.
- Keep storage areas clean and rodent free.
- Handle all bags with care eg fit pipes on sharp forklift tines.

- Re-bag damaged bags immediately.
- Sweep up spillage and dispose of sweepings in slurry pits or spread thinly on growing crops.
- Do not use sawdust as an absorbent.
- Notify the Fire Authority and Health & Safety Executive if 25 tonnes, or more, of ammonium nitrate is stored at any one time.⁽³⁾
- Develop contingency plans to contain contaminated firewater and prevent entry to drains or watercourses.

TEMPORARY FIELD STORAGE

- Do not store within 10m of ditch, watercourse or land drains.
- Return unused bags to a permanent store as soon as possible.

FLUID FERTILISER STORAGE

Farmers share a duty of care for siting, use and maintenance, even when fertiliser suppliers provide tanks.

Using tanks

- Ensure tanks, pipework and valves are fit for purpose, ie resistant to corrosion.
- Ensure all tank fittings are tamper-proof. Lock all valves shut when not in use.
- Ensure delivery companies are aware of emergency procedures.
- Ensure tank, pipework and valves are in good condition before deliveries are made.
- Check tank has sufficient capacity before delivery.
- Avoid overfilling.

Maintaining tanks

- Have tanks, pipework and valves inspected internally and externally, for damage and corrosion at least annually by a suitably qualified technician.
- Carry out any necessary remedial work immediately.
- Undertake additional checks at

the start of the season and when deliveries are made to and from the tank⁽⁴⁾. If in doubt do not use the tank or bowser.

- Drain down and flush through all pipework at the end of each season.
- Keep a maintenance record.

PERMANENT STORAGE

- Conduct an environmental risk assessment⁽⁵⁾. Advice is available from the Environment Agency.
- Construct secondary containment where environment assessment shows high risk. Use of reinforced masonry or concrete is recommended and provision should be made for at least 110% of tank capacity. Properly designed and constructed earth embankments may be an acceptable alternative. All pipes, valves and sight gauges should be within the containment area. (NB As a last resort, the Environment Agency can issue a works notice requiring secondary containment in high risk locations⁽¹⁾).
- Tanks must be on a solid, stable concrete base of footing to take the full tank weight.

- Consider additional stabilisation against high winds for GRP tanks.

BOWSERS AND MOBILE TANKS

- Temporary storage can pose a significant hazard to watercourses. Thus suitable siting is crucial before filling or dispensing. Transport around the farm needs careful consideration. Roadways and tracks must be able to withstand fully laden bowzers passing over or being parked on them.
- Ensure bowzers and all fittings are fit for purpose and protected from corrosion.
- Ensure bowzers are set down on level, solid ground before delivery is made.
- Provide sufficient support beneath parking legs to carry loaded weight without it sinking into the ground or becoming unstable.
- Ensure all hatches and manholes form a watertight seal when closed.
- Do not move laden bowser unless all hatches, lids and valves are closed and locked.
- Open hatches slightly, when emptying bowzers, to avoid a vacuum which could cause the tank to crumple and collapse.

DEALING WITH SPILLAGES, EMERGENCY PROCEDURES AND STAFF TRAINING

DEALING WITH SPILLAGES

- Contain any spillage wherever possible.
- Use inert absorbent materials, eg sand or earth, for liquid spills (not sawdust).
- Block gullies, drainage systems or other routes to watercourses.
- Do NOT hose down a spillage.

EMERGENCY PROCEDURES

- Identify routes to vulnerable watercourses and groundwater on your farm.
- Establish and test emergency procedures.
- Devise spillage, emergency and firewater procedures to provide containment areas near tanks, bowzers or stores.

Footnote

(4) Instructions for inspecting condition of fluid fertiliser tanks (free) – Agricultural Industries Confederation 01733 385230 or from website: www.agindustries.org.uk.

(5) Risk assessment guide on siting storage facilities (free) – Agricultural Industries Confederation 01733 385230 or from website: www.agindustries.org.uk.

- Consider blocking drains and damming watercourses as well as providing drain-blocking mats or drain bungs.
- Use leak-sealing putty on tanks and pipework for temporary repair.
- Inform and train everyone likely to become involved in dealing with a spillage or fire.
- Identify who to contact in the event of a spillage, loss or fire.
- Ensure all have access to important telephone numbers, eg local Environment Agency Office, fertiliser supplier and emergency services.
- Report any significant spillage to the farmer, the supplier and Environment Agency.

FURTHER INFORMATION

Code of good agricultural practice; Protecting our Water, Soil and Air' Download free from www.defra.gov.uk/publications or hard copy (£12.50) from www.tso.co.uk

The Environment Agency

Pollution Prevention Guidance Notes:

PPG2 – *Above ground oil storage tanks* – for containment wall information

PPG18 – *Pollution prevention measures for the control of spillages and fire fighting runoff* – for more detailed information about storing chemicals.

Policy and practice for the protection of groundwater

Ground Water Vulnerability Maps

Working in partnership to prevent pollution

Environment Agency – 24 hour Emergency Hotline 0800 807060

For non-emergency general advice, phone 03708 506506



Environment
Agency



CODE OF PRACTICE FOR THE PREVENTION OF WATER POLLUTION FROM THE STORAGE AND HANDLING OF FLUID FERTILISERS

PART 3 - USERS

2014



PRODUCED IN CONSULTATION WITH



PART 3 – USERS

This Code of Practice for the Prevention of Water Pollution from the Storage and Handling of Fluid Fertilisers (hereafter referred to as the 'Code') is in three parts:

PART 1 – SUPPLIERS

PART 2 – TANKER DRIVERS

PART 3 – USERS

The Code is published and recommended by the Agricultural Industries Confederation (AIC). The information is given in good faith and does not imply the acceptance of any legal liability or responsibility whatsoever, by AIC or by individual AIC members for the consequences of its use or misuse or in any particular circumstances.

PREFACE

As a user of fluid fertilisers, you are handling materials which, if spilled in quantity, can be very damaging to the water environment. This Code of Practice has been drawn up to help you to reduce the risk of causing water pollution as a result of losing fluid fertiliser during storage or handling at the farm.

There is clear economic benefit to the user in reducing losses of nutrients to the wider environment, whether from accidental spillage, poor management practices or vandalism. Any of these could result in water pollution which could have serious consequences, both legal and financial. The costs of pollution clean-up and any fish restocking for example would be charged to the polluter or relevant parties. With some forethought and planning for emergencies you should be able to answer the question: 'What would be the consequences of a major spillage of fluid fertiliser at your site?' You must know your site and the surrounding drainage system and what to do and how to react to an accident or emergency so as to minimise the chances of causing pollution.

Preplanning is essential so that you avoid having to deal with a real incident unprepared. Pollution of surface waters by fertiliser is a serious matter but at least it is possible to monitor it directly and carry out remedial action, albeit at some cost. If a major spillage of fluid fertiliser onto the ground is allowed to soak away, any groundwater contamination will be impossible to monitor except by costly techniques and may be impossible to remedy. Pollution of groundwater is potentially very serious because this water can be used

extensively for public drinking water supplies and for industrial and agricultural use. The environment agencies in England, Wales, Scotland and Northern Ireland have identified all groundwater resources and have specific policies for the protection of sources through the control of activities and development in close proximity to source extraction boreholes. Groundwater resources and extraction boreholes are valuable and expensive assets. It is essential that those storing and handling fluid fertilisers are aware of the vulnerability of nearby groundwater sources so that this can be taken into account when siting storage facilities and drawing up emergency plans. The objective must be to ensure that pollution is prevented and that in the event of a major spillage, fluid fertiliser is not allowed to soak through the soil directly, or by way of drains and soak-aways in these vulnerable areas.

If you require further more specific information about the sensitivity of your site with respect to the water environment the environment agencies are always pleased to offer advice. AIC also publishes a **Code of Practice for the Prevention of Water Pollution from the Storage and Handling of Solid Fertilisers**.

Please request a complete copy of the code if required.

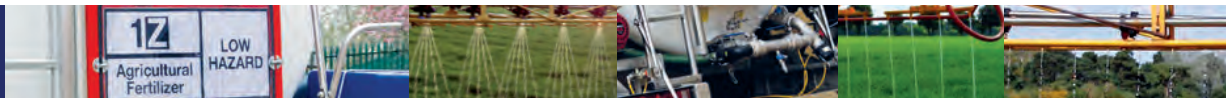

PART 3 – USERS

3.1 INTRODUCTION

3.1.1 This 'Code of Practice for the Prevention of Water Pollution from the Storage and Handling of Fluid Fertilisers, (Part 3, [Users])' is a practical guide to help users avoid loss or spillage of **fluid fertiliser** which could cause water pollution.

3.1.2 This Code is without prejudice to any legal obligations safety requirements or other codes of practice.

3.1.3 Following this Code is not a defence against a charge of causing pollution, although it should reduce the chance of pollution occurring and will help provide proof of due diligence and good working practice.

3.1.4 Users should ensure that they carry adequate insurance cover against liability for pollution.

3.1.5 This Code does not cover guidance for the appropriate usage of **fluid fertiliser**. Reference should be made to Protecting Our Water, Soil and Air: a Code of Good Agricultural Practice (Defra - England), Prevention of Environmental Pollution from Agricultural Activity (Scottish Government - Scotland), and the Code of Good Agricultural Practice (DARD – Northern Ireland), and also to published fertiliser recommendations. See Fertiliser Manual (Appendix 1).

3.1.6 This Code has been drawn up in consultation with the Environment Agency England, Natural Resources Wales, the Scottish Environment Protection Agency and the Northern Ireland Environment Agency. (Appendix 1)

3.2 DEFINITIONS

For the purposes of this Code, the term:

3.2.1 '**User**' shall mean the farmer, grower, application contractor and organisation or individual responsible for the end-use of fluid fertilisers. Delivery and transportation on the public highway is covered in part 2 of this Code.

3.2.2 '**Supplier**' shall refer to the manufacturer, importer, distributor, merchant, haulier or other organisation or individual who supplies the **user** with **fluid fertiliser**.

3.2.3 '**Tanker Driver**' shall mean the driver of any vehicle designed to transport and deliver liquid fertilisers in bulk or semi bulk Intermediate Bulk Containers (IBCs)

3.2.4 '**Fluid Fertiliser**' shall include all solution fertilisers (otherwise known a liquid fertilisers), suspension fertilisers and aqueous ammonia solutions not exceeding 34% ammonia Organic-based fluids containing plant nutrients such as farm slurries, AD Digestate, sewage sludges or other effluents are expressly excluded.

3.2.5 '**Bund**' shall mean a strongly constructed secondary containment with impermeable walls and floor.

3.2.6 '**Watercourse**' shall include all surface water whether coastal water, estuary, lake, pond, river, stream, canal and field ditch, (even when dry), unless it is a containment ditch.

3.2.7 '**Groundwater**' shall be defined as water which is below the surface of the ground in the saturation zone and in direct contact with the ground and/or water held in underground rock formations (aquifers). For the purposes of this Code it is considered that pollution of **Groundwater** could result from incidents occurring where such aquifers outcrop at or near the soil surface, or occurring within 50 metres of a water abstraction borehole, or where no protection of the underlying water exists e.g. where there are soakaways, swallow holes or quarries.

3.2.8 '**Major Spillage**' shall refer to a spillage which cannot be controlled and/or which involves significant loss of the spillage causing pollution of a **watercourse** or of **groundwater**.

3.3 GENERAL PRINCIPLES

3.3.1 Fluid fertilisers can be applied to a field very accurately, thereby avoiding unwanted and potentially damaging applications to field margins, hedge bottoms or ditches. As with all nutrient sources, including solid fertilisers and organic manures and wastes, care must be taken with their storage, transfer and transportation. Detailed guidelines are given but attention is drawn to six main points:

- Fixed or mobile stores must be sited with care,
- Any spillage which occurs must be properly dealt with to avoid pollution,

<ul style="list-style-type: none"> • Stores, valves and pipework must be properly maintained and inspected, and records kept, • Bowsers or tankers, before being moved, must have their hatches/ lids securely closed. • Valves must be secured so that they can only be opened by authorised personnel, • There must be a spillage contingency plan. Know what to do in an emergency. 	
<p>3.3.2 All procedures, equipment and installations should be designed to avoid any spillage of fluid fertilisers.</p>	<p>3.4.4 Existing sites, and preferably all new sites, should be in areas where groundwater vulnerability is low and not in highly sensitive areas. Sensitive areas are in the proximity of boreholes, wells, springs, aquifer outcrops, soak-aways, swallow holes, quarries or within 50 metres of abstraction for potable supply. For further guidance on groundwater protection contact the appropriate environment agency (Appendix 1) or refer to the Environment Agency web-based resource 'What's in your backyard' (See Appendix 1).</p>
<p>3.3.3 In the event of such spillage, appropriate procedures and resources should be in-place to prevent the pollution of watercourses or groundwater.</p>	<p>3.4.5 Where permanent storage tanks are unavoidably sited in a high-risk position, serious consideration should be given to the provision of appropriate bunding (Appendix 1).</p>
<p>3.3.4 Frequent inspections and regular maintenance should be made of all pipework, valves, tanks, bowsers, lagoons, hard-standing, bunds (if provided) and security systems to minimise the risk of accidental leakage or failure. Records should be kept of this maintenance and inspection.</p>	<p>3.4.6 Consideration should be given as to where any spilled fluid fertiliser would flow in the event of an accident during loading or unloading, or if the store were to develop a leak or be vandalised. Fire-fighting run-off also presents a risk. The total potential spillage must be capable of containment in an impermeable area. Where such areas are on the outcrop of an aquifer, the need to protect groundwater must be considered.</p>
<p>3.4 SITING OF FLUID FERTILISER STORAGE TANKS, LAGOONS AND BOWSERS</p>	
<p>3.4.1 Suitable siting of storage tanks, lagoons and bowsers is critical to avoid potential pollution of watercourses or groundwater in the event of any spillage.</p>	<p>3.4.7 The potential route of any escaping fluid fertiliser should be channeled to a suitable impermeable area by means of permanent soil banks and/or kerbs where necessary. Care should be taken to prevent any spilled fluid fertiliser from running down a road and thus into drains. Soil is a better and more absorbent temporary barrier than sand.</p>
<p>3.4.2 Good, well-constructed vehicular access for large delivery and off-take vehicles is essential. An impermeable hard-standing should be provided at the point of delivery to enable any minor spillage to be contained.</p>	<p>3.4.8 Care needs to be taken in every case with the appropriate siting of tankers, mobile tankers or bowsers. Tankers, mobile tanks and bowsers should all be sited so as to minimise the risk of any spillage of fluid fertiliser entering a watercourse or groundwater, even though such siting may be only temporary.</p>
<p>3.4.3 It should not be assumed that existing sites are correctly sited, even if no pollution problems have arisen. No site should extend to within 10 metres of a watercourse or a drain leading to a watercourse. Bunding of tanks is always recommended</p>	
	<p>3.4.9 No fluid fertiliser shall be received into bowsers supported on parking legs unless these legs are resting on made-up roadway or concrete of known and adequate thickness, or are resting on a support of suitable size and thickness, to support the loaded weight of the bowser without it sinking into the ground and becoming unstable.</p>

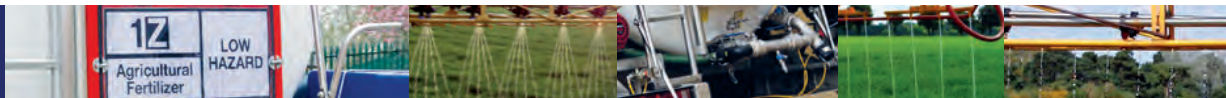

3.4.9 No **fluid fertiliser** shall be received into bowsters supported on parking legs unless these legs are resting on made-up roadway or concrete of known and adequate thickness, or are resting on a support of suitable size and thickness, to support the loaded weight of the bowster without it sinking into the ground and becoming unstable.

3.4.10 The **user** has a responsibility to consider and advise on the correct siting of any tankers or bowsters, including those supplied by a haulier or application contractor. The **user** should take into consideration the location of surface water drains and land drains. The **user** must take care to ensure that when laden tankers or bowsters are being moved on their property they are not driven so close to a **watercourse** or causeway that the bank is unable to support the weight. Weak bridges must be avoided.

3.4.11 **Fluid fertiliser** stores should be sited away from public access to minimise the risk of vandalism, with the outlet(s) and sight gauges securely locked or inoperable when unattended. The stores should be made as secure as feasible, with consideration given to deterrent lighting.

3.5 FLUID FERTILISER STORAGE

3.5.1 **Fluid fertilisers** may be stored in suitable above-ground tanks or, with the exception of aqueous ammonia, in suitably designed lagoons (see 3.5.6). They should not be stored in unsupported flexible containers.

3.5.2 Permanently-sited tanks and fittings must be fit for the purpose, must be of a suitable material resistant to corrosion and must be sited on a base or footing designed to support the weight of the full tank.

3.5.3 The outside of steel tanks should be protected against corrosion with a suitable paint.

3.5.4 Tankers, mobile tanks or bowsters should be fit for the purpose and should be of a suitable material resistant to corrosion. All hatches should have covers which provide a watertight seal when closed. No laden mobile tank or bowster should be moved unless all hatches, lids and valves are securely closed.

3.5.5 All outlet/inlet valve(s) and sight tubes/gauges should be positioned or protected so that they are not vulnerable to vandalism or accidental damage, particularly from passing vehicles. All valves should be inoperable when unattended, and on bunded tanks should be wholly within the bund. Sight tube valves/gauges should be fitted, closed and locked when not in use, and inside any bund.

3.5.6 With the exception of aqueous ammonia, **fluid fertilisers** may be stored in lagoons suitably designed and constructed with impermeable walls, floor and cover.

3.5.7 Users should conduct a thorough, formal and recorded check of all tanks, bowsters and lagoons at least once a year, in addition to normal everyday observation, for damage or corrosion which might give rise to leakage or failure. Appropriate measures should be taken to repair the storage if necessary and records kept of all inspections and repairs. Advice on inspection and maintenance should be sought from the **supplier** of the **fluid fertiliser**.

3.6 DELIVERIES AND TRANSFERS

3.6.1 A tanker driver delivering **fluid fertiliser**, who considers the condition of the store, valves, pipework, access or siting inappropriate, may refuse to off-load the delivery.

3.6.2 The **user** should be satisfied that the **supplier** of **fluid fertiliser** is operating in accordance with this Code, Part 1, [Suppliers], and has drawn up adequate emergency procedures for use in the event of a **major spillage** occurring during **fluid fertiliser** transfer onto farm. The **user** should ensure that they are able to assist as necessary to contain any spillage and to avoid pollution of any **watercourse** or **groundwater**. Routinely supply and use drip trays.

3.6.3 The **user** should draw up procedures for use in the event of a **major spillage** occurring on farm at times other than during delivery by the **supplier**. These procedures may involve the assistance of the **supplier** and of the appropriate environment agency. An emergency plan could usefully include drainage and potential containment points.



APPENDIX 1

SOURCES OF INFORMATION

Containment Systems for the Prevention of Pollution:

Secondary, tertiary and other measures for industrial and commercial premises. CIRIA (C736)
www.ciria.org.uk

Protecting our Water, Soil and Air: a Code of Good Agricultural Practice for Farmers, Growers and Land Managers, Defra, 2009.

The Stationery Office, ISBN 978 0 11 243284 5
www.gov.uk/government/publications/protecting-our-water-soil-and-air

Prevention of Environmental Pollution from Agricultural Activity

The Scottish Government, 2005, ISBN 0 7559 4106 3.
www.scotland.gov.uk/Publications/2002/06/14968/7848

Code of Good Agricultural Practice

DARD, 2008, ISBN 978 1 84807 068 4.
www.dardni.gov.uk/cogap

Fertiliser Manual (RB209) 8th Edition, 2010

The Stationery Office, ISBN 978 0 11 243286 9
www.gov.uk/government/publications/fertiliser-manual-rb209

SRUC Technical Notes: Fertiliser Series

www.sruc.ac.uk

Eurocode 2. Design of concrete structures. Liquid retaining and containing structures

BS EN 1992-3:2006
www.techstreet.com/products/1278297

Groundwater protection: Principles and practice (GP3)

www.environment-agency.gov.uk/research/library/publications/144346.aspx

Recommendations for Safe Storage and Handling of Wet Process Phosphoric Acid, (Phosphoric Acid Produced from Sulphuric Acid), 1991

EFMA, Avenue E Van Nieuwenhuyse 4, B-1160, Brussels
www.fertilizerseurope.com

Hazardous Properties of Ammonia, 1990

EFMA, Avenue E Van Nieuwenhuyse 4, B-1160, Brussels
www.fertilizerseurope.com

Code of Practice for the Prevention of Water Pollution from the Storage and Handling of Solid Fertilisers

Agricultural Industries Confederation, 2009, Confederation House, East of England Showground, Peterborough, PE2 6XE
www.agindustries.org.uk

Guidance for the Preparation of Safety Data Sheets for Fertilizer Materials 2008

EFMA, Avenue E Van Nieuwenhuyse 4, B-1660, Brussels
www.fertilizerseurope.com

FACTS

For details of the FACTS Scheme and its qualified advisers in crop nutrition
Tel: 01335 343945
www.basis-reg.com/facts

THE ENVIRONMENT AGENCY ENGLAND

Free emergency incident telephone number: 0800 80 70 60
General enquiries: 03708 506506
www.environment-agency.gov.uk

NATURAL RESOURCES WALES

Free emergency incident telephone number: 0800 807060
General enquiries: 0300 065 3000
www.naturalresourceswales.gov.uk

SEPA

Free emergency incident telephone number: 0800 807060
www.sepa.org.uk

NORTHERN IRELAND ENVIRONMENT AGENCY

Free emergency incident telephone number: 0800 80 70 60
www.doeni.gov.uk

ENVIRONMENTAL PROTECTION AGENCY IRELAND

National environmental incident
Telephone number: 1850 365 121
www.epa.ie

Photocopy this form to create your own records



FLUID FERTILISER STORAGE TANK ENVIRONMENTAL RISK ASSESSMENT FOR SPILLAGES

This assessment should be completed for all existing or proposed installations

Storage tank sited at

(use field or yard name if relevant)

Tank owner

Owner's address

(if different from location)

Date of assessment

Assessed by

Tank construction *(delete as appropriate)*: GRP/Steel/Other (please specify)

Max tank capacity

litres

gallons

Manufactured by

Date manufactured

Date installed

Maintained and serviced by

HAZARD	√ YES HIGHER RISK	x NO LOWER RISK
Tank situated where any spillage could enter an open drain, gully or loose fitting manhole cover draining to a ditch, watercourse, lake, pond, land drains or soakaway?		
Is the tank situated over ground or a hard surface that would convey any spillage into a ditch, watercourse, lake, pond, land drains, soakaway or to within 50 metres of a borehole, well or spring?		
Is the tank situated on a free draining, permeable surface?		
Is the tank situated in a position where it can not be observed during delivery or take off?		
Are there any other potential hazards individual to the site that could result in unacceptable environmental damage?		

One or more ticks in the Yes column indicate that the storage tank is at a higher risk. You are recommended to ensure that the tank is provided with adequately designed and constructed secondary containment system which should also enclose ancillary equipment such as the fill and draw off pipework connections.

Photocopy this form to create your own records



TANK INSPECTION CHECKLIST

Tank Location: _____

CHECK	Condition score			Repair required		Comments
	1	2	3	Yes	No	
Visible external corrosion						
Visible corrosion of welded seams						
Plastic tanks damaged, cracked or crazed						
Damp areas on outside of tanks (These may indicate pinhole leaks)						
Tank label						
Condition of inlet valve	Internal					
	External					
Condition of outlet valve	Internal					
	External					
Condition of glass support						
Condition of sight of glass valves						
Condition of tank paint work						
Security locks on fittings: (Inlet/outlet valves, delivery hatches, vent pipes and sight glass valves)						
Total Score						

Secondary Containment System Inspection Checklist (if installed)

CHECK	Condition score			Repair required		Comments
	1	2	3	Yes	No	
Floor of secondary containment system						
Walls of secondary containment system						
Roof of secondary containment system						
Housekeeping inside secondary containment system)						
Drainage outlet						
Adequate to contain 110% capacity of tank						
Total Score						

Secondary Containment System: An impermeable structure around a storage tank and ancillary equipment to allow the contents of the tank to be contained should a leak or spill occur. These systems may take various forms. For example: earth embankments, a brick bund or a metal bund. The ideal capacity of a secondary containment system should be a minimum of 110% of the tanks capacity.

Tank Inspection Score Indicators

Score	Priority	Condition
1-13	No repairs required	1
13-26	Some repairs required	2
26-39	Immediate repairs required	3

Secondary Containment System Inspection Score Indicators

Score	Priority	Condition
1-6	No repairs required	1
6-12	Some repairs required	2
12-18	Immediate repairs required	3

Guidelines for Action

Condition	Examples of faults found
1	Near perfect condition: Paint intact, no paint blisters. No corrosion of tank or valves. No cracks in secondary containment. Tanks supports in good condition. Tank is clearly labelled. Locks on all fittings, eg inlet and outlet valves and sight glass valve. No drainage outlet. No repairs required.
2	Adequate condition: Paint system flaking, but still adequate. Slight corrosion of tanks and valves. Some cracks in secondary containment system. Slight cracking around supports. Label is unclear or in wrong position. Locks only on some fittings. External drainage outlet with control valve. Some repairs required.
3	Bad condition: Paint system flaking badly, pitted or corroded; paint system ineffective. Tank and valves corroded. Secondary containment system badly cracked and retaining liquid. Cracked tank supports. Tank unlabelled. No security locks fitted. Bund ineffective. Immediate repairs required.

Signature: _____

Date: _____

Notes

A series of horizontal dotted lines for writing notes.



Distributed in Ireland by:

Sales - Luke Thornton -

+353 85 199 0899

LukeT@omex.com

OMEX Agriculture

Bardney Airfield

Tupholme

Lincoln

LN3 5TP

Tel 00 44 1526 396000

Email contact@omex.com

Web www.omex.com

