



# Liquid Fertilisers

Forage & Grassland

Product Guide



OMEX operates throughout the world manufacturing liquid fertilisers and foliar health promoters for the agricultural, horticultural and amenity sectors. Specialist knowledge of fluid dynamics has also allowed OMEX to expand into producing wastewater treatments and deicers.

The OMEX solution fertiliser range, Nitroflo<sup>®</sup>, includes some of the most concentrated liquid nitrogen fertilisers available in the UK. They are delivered for farmer application and offer many advantages over conventional solid fertiliser in terms of accuracy, consistency, ease of use, reduced environmental impact and increased yield potential.

[www.omex.co.uk](http://www.omex.co.uk)

## Nitroflo<sup>®</sup> Storage Sites

OMEX liquid fertiliser is made in the UK, with a storage and distribution network that is unrivaled in the industry, ensuring a fast and efficient delivery to farm, even during peak periods.

Hubs strategically located throughout the UK service, OMEX's main manufacturing sites at Bardney and King's Lynn, and inland distribution centres near Swindon, Scotch Corner and Shrewsbury. All sites are able to produce the full range and deliver to farms directly.

A tank rental scheme enables farmers to take advantage of seasonal pricing and be prepared for the first weather breaks in early spring.

OMEX's extensive storage facilities are well stocked before the peaks, ready to supply to farms around the UK on demand, giving an excellent delivery service when it counts.



### Central Distribution

Distribution - T: 01526 396014

Bardney Airfield, Tupholme, Lincoln, Lincolnshire LN3 5TP

T: 01526 396000

E: [deliveries@omex.com](mailto:deliveries@omex.com)

# CONTENTS

## Benefits of Nitroflo Liquid Fertiliser

- 4 Summary of Benefits
- 4 Potential Fixed Cost Savings
- 5 Accuracy
- 5 Productivity of Field Margins
- 6 Silage Grass
- 6 Three Sources of N
- 7 Application

---

## Liquid Fertiliser and the Environment

### Products

- 9 Nitroflo® Range
- 10 Nitroflo® on Grass
- 12 Didin®
- 14 Sulphur
- 15 Solution Compound Fertilisers
- 16 Starter Fertiliser

---

### Application Information

- 17 Quick Guide to Converting to Nitroflo
- 18 Application Charts - Solution Compounds
- 20 Application Charts - Nitroflo Range
- 28 Application Bars and Nozzles
- 29 OMEX Streambar

## Tank Storage Scheme

- 34 Rental Scheme for 30m<sup>3</sup>, 40m<sup>3</sup> and 50m<sup>3</sup> GRP Tank
- 36 Base and bund requirements for GRP Vertical Tank 30m<sup>3</sup>/40m<sup>3</sup>/50m<sup>3</sup>

---

### Notes

- 32 Protecting the Environment - AIC
- 34 Users Code of Practice - AIC
- 43 Notes

# Benefits of Nitroflo<sup>®</sup> Liquid Fertiliser

The OMEX Nitroflo liquid fertiliser range includes some of the most concentrated products available in the UK and Ireland.

They are delivered for farmer or contractor application and offer many advantages over conventional solid fertiliser application in terms of accuracy, consistency and ease of use. By using OMEX Nitroflo liquid fertilisers, farmers save time, protect the environment, and maximise crop yields.

All OMEX liquid fertilisers are supplied in bulk, eliminating packaging and the need to recycle waste, and provide major handling and storage advantages over solid fertilisers.

## Summary of Benefits

- Accurate application up to field margins
- Three sources of nitrogen - ammonium, nitrate and urea - so the best balance between availability to crop when needed and reduced risk of loss through leaching
- Effective across a full range of crops, including grass & forage crops
- No off-loading costs as Nitroflo is pumped directly into holding tanks on-farm
- No bag disposal
- Faster response to application on silage ground after first cut, especially in dry conditions
- Improved application accuracy. Tests show that application by granular spreader often vary by 20% across the spread width. Farm sprayers are unlikely to vary by more than 5%
- Better utilisation of time and labour - Nitroflo can be applied in less favourable conditions, when applying solid fertilisers or crop spraying would not be possible
- Higher work rates. It takes just a couple of minutes for one man to load the sprayer with Nitroflo
- An opportunity to upgrade sprayer and increase tramline widths, increasing the cropped area, work rates and accuracy of top-dressing

## Potential Fixed Cost Savings

Perhaps one of the best times for a farmer to consider converting to liquid fertiliser is when the farm sprayer or spreader is due for renewal or tramline widths are increased. It is at these points that there is an opportunity to consider the effective utilisation of labour and machinery and the respective fixed costs.

**Low-Labour Application System** - Liquid fertiliser offers a low-labour application system compared with solid fertiliser:

- No offloading with a forklift
- No storage in a secure building
- No re-loading and carting to field
- No dust, no bag disposal
- No wastage (unused fertiliser is returned to the tank)
- No need for a second man to load the spreader

**Low Cost Storage** - Low cost GRP storage tanks are available through rental schemes (see pg 34).



## Accuracy

**Accuracy of Application** - The accuracy of application of nitrogen fertiliser has a major impact on gross margins. Variability across a spreading width is referred to as the coefficient of variation (CoV). The graph shows the impact on profitability as the CoV increases for winter wheat. It is not impossible for solid spreaders to operate with CoVs of 30-40% if they are poorly calibrated or

maintained, and 20% is a common average figure. It is only above 20% CoV that striping becomes visible, by which time the financial loss is £15/ha.

Nitroflo is applied by sprayer with an average CoV of 5%, consequently, application of Nitroflo could improve gross margins by £12/ha compared with a spinning disc spreader.

### OMEX Nitroflo 26S on Silage Ground

Nitroflo 26S applied to 2nd cut silage stubble:



Nitroflo 26S applied 22 June 2020



Same crop 16 DAT on 9 July 2020

## Productivity of Field Margins

Ensuring nitrogen is applied at full rate to the edge of the field but no further is a key issue. Despite ongoing advances in spreader design, it is not possible for a spinning disc to apply an even distribution pattern if the operator is to guarantee that no fertiliser travels beyond the edge of the field.

Yield loss from the outside 8m of a field has been shown to be 3.5t/ha of winter wheat and 10t/ha of potatoes when nitrogen is applied through a

spinning disc spreader. The outside 8m of a 15ha field represents 5% of the field, so the yield loss would be 2.63t, worth £420 (wheat at £160/t). A farmer growing 400ha of winter wheat could be losing over £11,000 across the outside 8m of their fields.

By using Nitroflo, it is possible to apply the full rate of nitrogen right up to the field margin: no compromise to yield, no risk of applying fertiliser beyond the field margin.

Average Field Size	% Area in Outside 8m	Yield Loss		
		Outside 8m WW (t)	Yield Loss 100ha WW	£ Loss at £160/t
20ha	4.00%	3.5	14	£2,240
15ha	5.00%	3.5	17.5	£2,800
10ha	5.50%	3.5	19.25	£3,080
8ha	6.00%	3.5	21	£3,360
5ha	7.50%	3.5	26.25	£4,200
4ha	8.50%	3.5	29.75	£4,760

*"Liquid N? It's a "No Brainer", the best thing I've done for a long time. It is taken up more quickly by the crop, a one-man operation, no striping, and more grass per application."*

**Mark Jeanes, Lower Bagber Farms Ltd, Dorset. Dairy Farmer.**

## The visual impact of using Granular compared to Nitroflo accuracy:

### Grassland



### Grassland



## Silage Grass

The picture sequence below shows a field a ter second cut silage.

The crop was cut on 16 July, pick ed on 17 July, then grazed for two days. On 20 July OMEX Nitroflo S was applied at a rate of 112k g/ha (90 units/ac). Despite the drought, uptake of N was very rapid and a visual difference could be seen within two days.

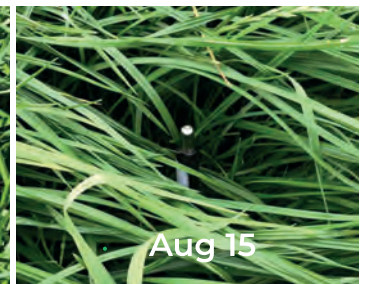
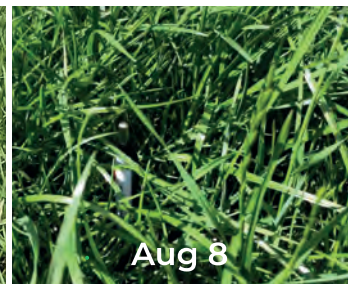
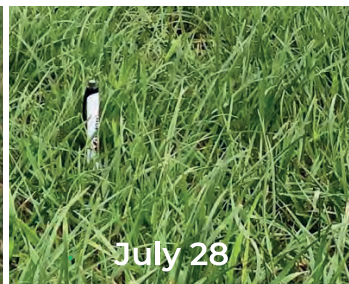
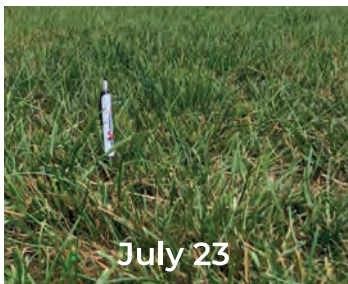

## Three Sources of N

Replicated plot trials by independent organisations have demonstrated the yield advantage of liquid nitrogen, compared to solid ammonium nitrate and urea. These yield benefits are a result of the blend of nitrogen sources in Nitroflo, which supply a balanced delivery of nitrogen to the crop, along with the superior application accuracy. The visual impact of liquid vs solid application is particularly evident in dry spring seasons when solid nitrogen is less available to the crop when needed.

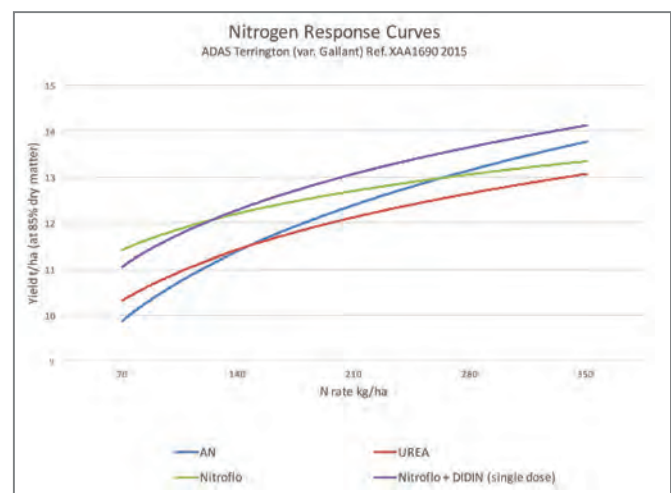

## Application

Nitroflo can be applied across a range of weather conditions including situations when solid nitrogen or agrochemicals cannot be applied. Nitroflo can be applied during rainfall, if ground conditions allow. It can be applied in breezy conditions because, unlike spray from a fan jet, the wind will not cause drift of a vertical stream and booms can be lowered to just above crop height. It is best to avoid damp leaf conditions (for example when a dew is lifting) since the nitrogen can spread on the leaf and be absorbed rapidly; in these conditions some scorch is possible.

**Less Pollution Risk** - By using Nitroflo it is possible to apply the full rate of nitrogen right up to the field margin without losing fertiliser beyond the boundary into the hedge bottom or close to dykes etc. This significantly reduces the risk of polluting water courses without incurring a yield loss along the field margin. Furthermore, since only 25% of the nitrogen sources is nitrate N there is much less risk of leaching shortly after application than with calcium ammonium nitrate (CAN) & ammonium nitrate (AN)



**Use Existing Sprayer** - Nitroflo can be applied through any farm sprayer. The only conversion required is to fit suitable nozzles. The best jets are those that apply even quantities in vertical streams across the full boom width, because they remove any variability caused by gradient and boom height. Consequently OMEX recommends the OMEX Streambar.

**Nitrogen & Sulphur Together** - By using one of the Nitroflo-S formulations, the farmer can apply nitrogen & sulphur together. The sulphur is included in sulphate form making sure both nutrients are available when needed. The range of sulphur grades allow the farmer to fine tune the sulphur application in season if required.

**More Crop Available in Dry Conditions** - As soon as Nitroflo is applied it is drawn into the soil. So, even in the driest of springs nitrogen starts becoming available to plants shortly after application.

Application Guidelines	
Do	Don't
Do apply when the crop is wet or in the rain	Don't apply when the crop is just damp and drying off – this may lead to a smear of nitrogen drying on the leaf, leading to too much leaf uptake
Do apply in the dry	Don't apply in the heat of the day or when >20°C between max and min is expected
Do apply in wind so long as streams are not being deflected by wind	Don't apply in wind once feathers of small droplets are being blown from the main stream, or if the wind has caused leaf bruising
Do keep forward speed slow and pressure low	Don't go above 2 bar pressure unless you really have to
Do apply in the evening or early morning if possible	Don't apply to the flag leaf (or leaf 2 if possible)
In sequence: Do apply fertiliser first and agrochemicals second. Leave a 2 day gap if possible	In sequence: Don't apply agrochemicals first – they are likely to de-wax the leaves and increase to risk of foliar uptake of N. Leave a 5 day gap if possible
Do keep grazing stock out for 5 days if there has been no rain	Don't dilute liquid nitrogen, it increases the risk of scorch

# Liquid Fertiliser and the Environment

Liquid nitrogen fertilisers offer great advantages with easy and accurate application and they are based on a non-hazardous solution of ammonium nitrate, ammonium sulphate and urea. The different nitrogen sources give a range of nitrogen release characteristics to crops. The nitrate content is immediately available, the urea content takes a little time to convert to nitrate and the ammonium content is somewhere in between. The plant-available nitrogen is therefore released more slowly than from nitrate-based products, reducing the risk of nitrate leaching and nitrous oxide losses during wet times and in waterlogged soils.

Nitrous oxide is a powerful greenhouse gas and can also break down to nitrogen oxides that can result in ozone depleting reactions (breaking down the ozone layer). Nitrous oxide has a global warming potential around 300 times greater than carbon dioxide, but unlike carbon dioxide, there is no natural absorption of nitrous oxide so it can remain in the atmosphere for hundreds of years.

The use of liquid nitrogen can therefore reduce the risk of nitrous oxide emissions, reducing the risk of global warming and nitrate leaching, reducing the risk of groundwater pollution.

The urea content of liquid nitrogen may be thought to have a potential to lose ammonia gas (volatilisation), a common issue with solid urea. The risk is much lower with liquid nitrogen as the urea is already dissolved, so enters and is drawn into the soil, protecting it from the risk of losses.

Liquid nitrogen plus sulphur therefore offers one of the best options in terms of accuracy of application, prevention of pollution of field margins and protection from nitrogen losses. However, if there are localised concerns about the specific risk of nitrate leaching or ammonia volatilisation, liquid nitrogen offers the flexibility to tank mix nitrification inhibitors (to delay the release of nitrate) and urease inhibitors (to delay the production of ammonium nitrogen) if required.

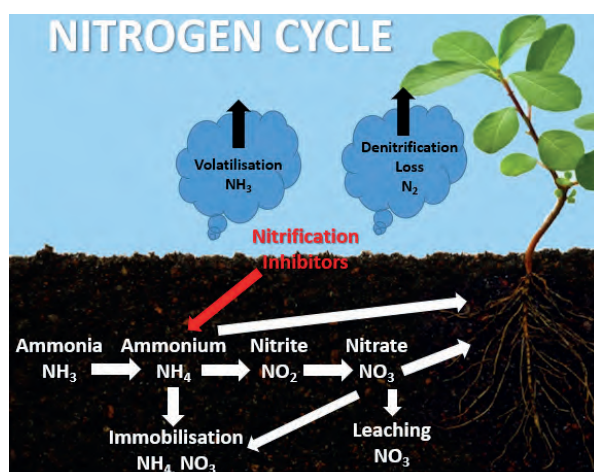

# Products - OMEX Nitroflo® Range

All fertilisers, including liquids, have to be invoiced by a guaranteed weight. Therefore, and to avoid confusion, all OMEX fertilisers are sold by weight and easy to use conversion charts are provided to give application volumes.

## The range includes:

**Nitroflo 30** - the most concentrated liquid nitrogen. The nitrogen source in Nitroflo is UAN - 50% of N sourced from urea, 25% from ammonium N and 25% from nitrate N.

**Nitroflo 26+S** - containing nitrogen and sulphur; for top-dressing sulphur responsive crops in the spring during periods of rapid growth. The sulphur source is sulphate.

**Nitroflo 24+S** - containing nitrogen and a higher level of S than Nitroflo 26+S. The sulphur source is sulphate.

**Nitroflo 22+S** - containing nitrogen and a higher level of S than Nitroflo 24+S. The sulphur source is sulphate.

**Nitroflo 20+S** - containing a higher level of sulphur; for deficient areas and crops with a high demand for sulphur, such as oilseed rape. The sulphur source is sulphate.

**Nitroflo 30+Didin** - allows growers to use just a single application to meet a crop's entire nitrogen requirement, saving application costs, improving yields and reducing nitrogen losses.

For application charts see page 18, or ask for a copy of the handy application chart

Product	Analysis w/w		SG	Approximate Analysis w/v		
	N	SO <sub>3</sub>		N	SO <sub>3</sub>	
Nitroflo 3	30%		1.30	39%		390kg/1000 litre
Nitroflo 28+	28%	2.5%	1.29	36%	3.2%	360kg N 32kg SO <sub>3</sub> /1000 litre
Nitroflo 26+	26%	5%	1.28	33.3%	6.4%	333kg N 64kg SO <sub>3</sub> /1000 litre
Nitroflo 24+	24%	7.5%	1.27	30%	9.5%	307kg N 96kg SO <sub>3</sub> /1000 litre
Nitroflo 22+	22%	10%	1.26	28%	12.5%	279kg N 127k g SO <sub>3</sub> /1000 litre
Nitroflo 20+	20%	12.5%	1.25	25%	15.5%	252kg N 158k g SO <sub>3</sub> /1000 litre
Nitroflo 15+	15%	15%	1.23	18.5%	18.5%	185k g N 185k g SO <sub>3</sub> /1000 litre



# Nitroflo® on Grass

**Nitroflo can be used instead of solid N on all types of grass. These are the key advantages:**

- Post cut or grazing, grass will respond to Nitroflo more quickly than solid N
- Daily gain in dry matter is larger when using Nitroflo
- Even in drought conditions new growth following uptake of N can be seen within 36 hours
- All the benefits of accurate application still apply in grass
- Nitroflo S contains sulphur in a form that is immediately plant available

## **Nitroflo S v Urea**

A New Zealand style grazing dairy unit in Staffordshire applied OMEX Nitroflo S on the same day as urea on adjoining grazing paddocks. The pictures below, taken at the same time, show the difference in DM production following application of Nitroflo Liquid Nitrogen.



*"I used Nitroflo 26S for the first time this year. I liked the accuracy across the field and no overlapping the ins and outs with auto-shutoff. I noticed far less secondary growth in my spring malting barley compared with what I saw in crops that had solid. I put this down to the more rapid uptake in dry conditions. We also saw fast regrowth on 2nd cut silage.*

*The tank installation guys were very efficient and professional. The fact that the liquid is stored in its own tank is fantastic as it doesn't take up shed space during the season."*

**Paul Mernagh, Goolamurry Farms Ltd. Co. Wexford. Farmer.**

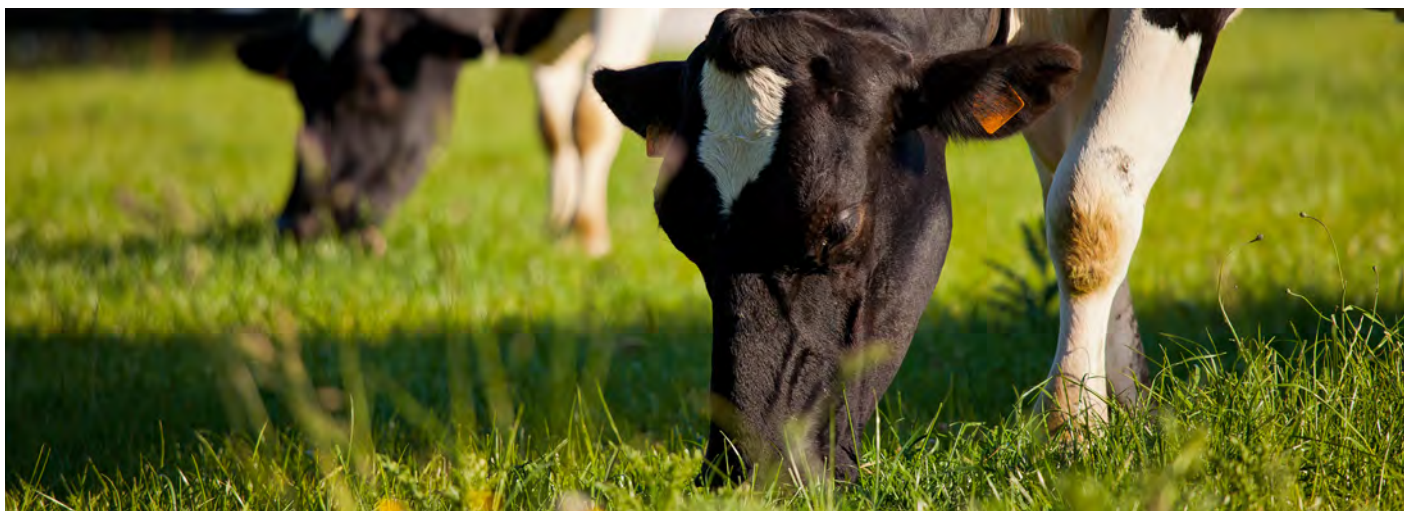

## OMEX Nitroflo® vs SulfaCAN

South Tipperary- June 2020

Two paddocks Perennial Ryegrass, both reseeded on the same day.

9th of June	LHS - 34 kg/ha N SulfaCAN	RHS - 31 kg/ha N Nitroflo 26S
<p><b>After 14 days:</b> <b>53% more grass</b> <b>with less units of</b> <b>nitrogen</b></p>		
	LHS - SulfaCAN	RHS - Nitroflo 26S
kg/ha of Nitrogen	34	31
Weight of grass within a quadrant	190g	340g
DM% of harvested grass	15.58	14.24
Kg/Ha of yield	1260	1936
Days growth Post fertiliser	14	14
Growth/day-Kg DM	90	138
M.E. MJ/KgDM	11.84	12.13
Protein %	23.7	25.13
DMD%	79	81.15

## OMEX Nitroflo® vs Protected Urea

North Tipperary- July 2020

Two paddocks side by side of Perennial Ryegrass.

4th of July	LHS - 34 kg/ha N Protected Urea	RHS - 34 kg/ha N Nitroflo 26S
<p><b>After 14 days:</b> <b>65% more grass</b> <b>with same units of</b> <b>nitrogen</b></p>		
	LHS	RHS
kg/ha of Nitrogen	34	34
Quadrant	170g	280g
DM%	15	14
Kg / Ha	1020	1680
Days growth Post fertiliser	14	14
Growth/day-Kg DM	78	120

**Didin is a unique nitrogen stabiliser. When added to fertiliser or organic manures and applied to the soil it controls the release of crop-available nitrogen. It allows nitrogen to be applied in a single dose, eliminating the need for repeated applications, saving both time and money. It increases yields and dramatically improves the value of winter-applied slurry and AD digestate.**

- Reduces growing costs
- Reduces nitrate leaching
- Improves value of slurry
- Improves yield and quality
- Simplifies nitrogen management
- Reduces the carbon footprint of applications

### Trial Results and Yield Benefit

Trials by a wide range of organisations over many years have shown consistent yield advantages in crops treated with Didin. By including Didin with any nitrogen applications, the nitrogen is used more efficiently by the crop helping improve yield and quality by reducing nitrogen losses and optimising nitrogen delivery to the crop.

Crop	Number of trials	Average yield increase - t/ha	Average yield increase - %
Silage Maize	8	6.40	13.6%
Grassland	8	0.60	13.3%

### Didin in the Soil

Ammonium and urea based nitrogen fertilisers need bacteria to convert them from being relatively immobile to the highly mobile and plant available nitrate form. Didin inhibits the activity of the soil bacteria that convert this ammonium-N into nitrate-N, helping reduce nitrate leaching and creating a phased release of crop available nitrogen. As soil temperatures increase and crop growth begins, Didin progressively releases more nitrate nitrogen into the soil. After the inhibition has ceased the Didin is totally converted to plant-available nitrogen, leaving no residues in the soil.

### Didin for Grass

Silage grass – Didin can be used with most sources of nitrogen. For best use tank mix with OMEX Nitroflo. Apply all early spring nitrogen in one go as Nitroflo + Didin. After 1st cut, apply all of the nitrogen for 2nd and 3rd cut as Nitroflo and Didin.

Grazing grass – The number of repeat applications can be reduced by applying two doses at once with Didin. This reduces the cost of applications but maintains a constant feed of nitrogen to the crop.

### Didin with Organic Manures and AD Digestate.

Didin helps convert slurry, manure and the digestate from anaerobic digestion from being waste products into valuable fertilisers. It conserves the nitrogen through the late winter/ early spring, reducing the risk of nitrate leaching and phases the release of nitrate during the following spring and summer, reducing the requirement for additional nitrogen top-dressing. It also helps reduce losses of nitrous oxide following denitrification in waterlogged soils and increases crop yield and quality.

### Didin for Maize

When using Nitroflo on maize, apply all the nitrogen pre-drilling or pre-emergence with Didin. This works well when maize is being grown under polythene.

### Didin Directions for Use

**Liquid Fertiliser:** Add half the fertiliser to the spray tank, add the required amount of Didin whilst agitating. Add the remaining fertiliser and maintain agitation whilst spraying.

**Granular Fertiliser:** Apply before application of granular fertiliser using spray nozzle. Apply in a minimum of 200L/ha water.

**Organic Manures:** Ensure the Didin and slurry are well mixed. If using an umbilical cord system use a proportional injection system. If using a slurry tanker add Didin during filling. Didin can also be sprayed on before spreading the organic manure.

Type of Fertiliser/Crop	Timing	Soil Type	Rate
Liquid Nitrogen Fertiliser/Ammonium Nitrate	Spring	Light Medium Heavy/Peat	12.5L/ha 10L/ha 8L/ha
Granular/Prilled Urea	Spring	Light Medium Heavy/Peat	10L/ha 6L/ha 6L/ha
Liquid Fertiliser on <b>Potatoes</b> -Broadcast - Injected	Spring Spring	Light Light	12.5L/ha 6L/ha
Organic Manures, Slurry and AD Digestate on <b>Arable Crops</b>	Autumn Winter Spring		20-25L/ha 15-20L/ha 10-15L/ha
Organic Manures, Slurry and AD Digestate on <b>Grass</b>	Autumn Winter Spring		15-20L/ha 10-15L/ha 10L/ha

# Sulphur

**Sulphur is a vital element for plants and is required in similar amounts to phosphate in most crops.**

Sulphur deposition has decreased dramatically over the last 30 years, as a result of the Clean Air Act. Deficiencies of this vital element are now visible in many areas of the UK. Where deposition is less than 10k g/ha/year most crops will benefit from applications of fertiliser containing sulphur.

Responses to sulphur vary according to soil type, with greater responses likely on light or sandy soils. The level of response is affected by over winter rainfall on loam and coarse silty soils, with high rainfall increasing the likelihood of a significant yield increase. Clay, fine silts and organic soils have a lower likelihood of yield responses, except in areas with medium to high winter rainfall, where there is a medium chance of a yield response.

## How much to Apply

The continued reduction in sulphur deposition means that many rural areas of the UK currently receive less than around 5kg/ha of S from the atmosphere. The following recommendations take this into account.

## Maize

Historically, maize was grown in rotations with often large inputs of manure and slurry, which usually provided sufficient sulphur for the crop. With maize being increasingly grown outside livestock areas it is important to consider the sulphur requirement of the crop with an application of 50-75kg/ha SO<sub>3</sub> particularly on light soils is usually required.

## Grassland

Sulphur deficiency reduces the yield and quality potential of grassland and is exacerbated by high forage removal rates. Responsive crops require approximately 40kg/ha SO<sub>3</sub> Top-dressing with Nitroflo 20+S provides immediately available sulphur to supply the crops needs.



Sulphur deficiency in Maize

# Solution Compound Fertilisers

**OMEX solution compound fertilisers are true compounds; every drop contains the complete analysis. They cannot segregate and as a result every square centimetre of soil is guaranteed to receive the required ratio of nitrogen, phosphate and potash. Solution compounds are ideal for placement on potatoes and other crops, where the fertiliser can be very accurately placed in the soil.**

## **NPK Solutions**

The OMEX solution compound range offers accurate application of fertiliser for a wide range of situations, from pre-drilling to post-emergence. Most requirements can be supplied from the standard range of compounds, however OMEX also offers a custom blending service, providing an almost infinite range of analyses if necessary.

## **NPK+S Solutions**

OMEX solution compounds can also be supplied containing sulphur. Since the inclusion of S dilutes the NPK, the maximum inclusion rate is limited to 5SO<sub>3</sub>

## **Placement**

The close positioning of fertiliser in relation to crop roots can have a significant effect on the nutrient use efficiency of the fertiliser. Placement with solution fertilisers offers significant advantages over solid placement; precision positioning is guaranteed and the nutrients are all fully dissolved, offering rapid crop response. Handling is minimised, with pumps carrying out all transfers without bag handling and disposal. Placement of liquid compound fertiliser on potatoes can increase yields by 10-15%. Liquid nitrogen placement for vegetable and salad row crops results in more rapid and even establishment of transplants and provides prolonged nitrogen response for long-season crops. Starter doses of nitrogen and phosphate for crops such as maize can dramatically improve establishment rates.

## **Starter Fertiliser**

Liquid nitrogen, with or without phosphate, applied with cultivation drills and sub-soilers can significantly improve the establishment of maize or oilseed rape and phosphate can help enhance rooting. Since the phosphate is fully water soluble it is more accessible to the plant at the peak time for early root development. Application of low doses of nitrogen and phosphate helps establishment but does not remove the need to replace nutrients taken up throughout the life of the crop, otherwise soil reserves will be depleted.

## **Combined Drilling with Liquid Fertiliser**

Most modern drills can be adapted to allow a liquid fertiliser applicator to be fitted, providing the opportunity to place starter fertiliser in the row or surrounding the seed of any drilled crop. OMEX NPK solutions can be applied alone or in conjunction with micronutrients or phosphites, as required by the crop. The system allows for complete flexibility whilst providing the best possible environment for plant establishment.

## **Precision Farming**

OMEX solution fertilisers offer the ideal fertiliser delivery system for variable rate application. Modern flow controllers can simply be upgraded to provide variable rate fertiliser application, based on application maps from a number of sources; active crop sensors, remote sensing, soil testing or from an agronomist's field experience. Many of the UK's most innovative precision farmers use liquid fertilisers due to the ease of controlling the application rates and the ability to automatically regulate individual boom sections.

# Starter Fertilisers

Placement of NP on Maize offers an ideal opportunity to place a starter fertiliser in the root zone of the establishing plant.

To ensure that a crop gets off to a good start, it needs feeding. The best way to do this is to place a starter fertiliser precisely where it is required, effectively creating a nutrient rich seedbed for the crop. OMEX solution fertilisers offer the most effective means of accurately placing nutrients with 100% solubility in the right place for the emerging seedling.

OMEX liquid starter fertilisers are also ideal for placement on drills for other crops, such as cereals, maize, and sugar beet.

## Products and Recommendations

Tables below show application rates in l/ha to apply 30-60kg/ha of N (24-48 units/ac):

**Nitroflo 30:** contains 39 kg nitrogen per 100 litres product. For use where only nitrogen is required.

**OMEX 17-8-0:** contains approximately 21 kg nitrogen and 10 kg phosphorus per 100 litres product. For use where a phosphate starter effect is required.

Nitroflo 30		Percent of Field Covered by Fertiliser Bands				
kg/ha Applied In the Band		10%	20%	25%	33%	50%
N	P <sub>2</sub> O <sub>5</sub>	Application rate l/ha				
30		8	15	19	31	38
40		10	21	26	34	51
50		13	26	32	42	64
60		15	31	38	51	77
Nitroflo 30N		39 kg N per 100 litres of product				

17-8-0		Percent of Field Covered by Fertiliser Bands				
kg/ha Applied In the Band		10%	20%	25%	33%	50%
N	P <sub>2</sub> O <sub>5</sub>	Application rate l/ha				
30	14	14	29	36	57	71
40	19	19	38	48	63	95
50	24	24	48	60	79	119
60	28	29	57	71	94	143
17-8-0		21 kg N per 100 litres of product 10kg P <sub>2</sub> O <sub>5</sub> per 100 litres of product				

## Advantages of OMEX liquid starter fertilisers

- Major saving in autumn nitrogen requirement, up to 75%
- All of nitrogen captured by crop, reducing risk of leaching loss
- Fully soluble phosphate
- No dust, no blockages
- Precise targeting of nutrients
- Flexibility to work well within NVZ nitrogen limits
- Available with Polymex

**OMEX 14-14-0:** contains approximately 17 kg nitrogen and phosphorus per 100 litres product. Provides greater starter effect.

**OMEX 7-20-0:** contains approximately 9 kg nitrogen and 25 kg phosphorus per 100 litres product. Traditional starter fertiliser, provides full starter rate of phosphate.

14-14-0		Percent of Field Covered by Fertiliser Bands				
kg/ha Applied In the Band		10%	20%	25%	33%	50%
N	P <sub>2</sub> O <sub>5</sub>	Application rate l/ha				
30	30	18	35	44	71	88
40	40	24	47	59	94	118
50	50	29	59	74	118	147
60	60	35	71	88	141	176
14-14-0		17 kg N & P <sub>2</sub> O <sub>5</sub> per 100 litres of product				

7-20-0		Percent of Field Covered by Fertiliser Bands				
kg/ha Applied In the Band		10%	20%	25%	33%	50%
N	P <sub>2</sub> O <sub>5</sub>	Application rate l/ha				
20	57	22	44	56	73	111
30	86	33	67	83	110	167
40	114	44	89	111	147	222
50	143	56	111	139	183	278
7-20-0		9 kg N per 100 litres of product 25kg P <sub>2</sub> O <sub>5</sub> per 100 litres of product				

# Quick Guide to Converting to Nitroflo

To convert to Nitroflo liquid N is simple and not expensive.

## Application:

- You will need to buy a set of nozzles designed to apply liquid N. Remember, the target is the soil, not the crop. (See pages 28-29)
- Check with your sprayer dealer that your sprayer is set up to apply liquid fertiliser. (Most sprayers built in the last 10-15 years are)
- Alternatively, there is now a good network of contractors who can apply liquid N; contact your local OMEX distributor.

## Storage:

- If you just want to try the product, storage is not needed, OMEX will supply small quantities in IBCs.
- Once you have decided you want your own storage facility, you can rent a storage tank from OMEX (see pages 30-33). You will need to build a concrete base and bund. OMEX will help advise where and how best to do this.

## Buying Nitroflo:

- You can buy IBCs of Nitroflo from your OMEX distributor at any time during the season.

- You can buy bulk loads either pre-season or in-season.

## Delivery:

- IBCs are delivered within a couple of days by the distributor.
- Bulk loads arrive directly from OMEX. Delivery is usually within 72 hours in-season, but can be done more quickly if urgent.
- Bulk loads should be discharged into fertiliser tanks positioned inside a bund.
- In season, bulk loads can be discharged into temporary storage containers provided environmental safety conditions are met and there is someone available to help.
- Road tankers can be filled provided there is a tractor unit or bogey carrying the pin. Bowsers can be filled provided they are firmly attached to the trailer or running gear; both must be positioned on level hard standing and the vessel suitable for bottom filling.
- Bulk loads can be discharged into IBCs if this is arranged at time of order

## Frequently Asked Questions and Comments

Q "Isn't liquid fertiliser often associated with scorch?"

A Current application methods have virtually eliminated scorch and by following a few simple guidelines, scorch is not a problem

Q "Surely liquid nitrogen is too expensive?"

A The price of OMEX liquid nitrogen has for many years been competitive against UK produced ammonium nitrate

Q "Liquid nitrogen is corrosive."

A All nitrogen fertilisers can be mildly corrosive to unprotected steel. By cleaning down a sprayer after applying fertiliser, the sprayer condition will deteriorate no more than if it was used for conventional spraying alone

Q "There is a risk of urea volatilising in warm weather."

A The Nitroflo range contains liquid urea which rapidly enters the soil and is stabilised, reducing the risk of ammonia losses compared to solid urea

Q "Isn't it expensive to convert to liquid?"

A The cost of converting should be as little as the cost of a bunded concrete plinth for a storage tank and a set of nozzles. The storage site will be assessed by OMEX, the cost of bunding over the life of the site is low and the cost of storage tank is subsidised by OMEX.

# Application Charts – Solution Compounds

OMEX 16-0-8			
kg/ha N	kg/ha P <sub>2</sub> O <sub>5</sub>	kg/ha K <sub>2</sub> O	l/ha
10	0	5	54
20	0	10	108
30	0	15	162
40	0	20	216
50	0	25	269
60	0	30	323
70	0	35	377
80	0	40	431
90	0	45	485
100	0	50	539
110	0	55	593
120	0	60	647
130	0	65	700
140	0	70	753
150	0	75	808
160	0	80	862
170	0	85	916
180	0	90	970
190	0	95	1024
200	0	100	1078
Specific Gravity (SG): 1.16			

OMEX 15-3.5-7.5			
kg/ha N	kg/ha P <sub>2</sub> O <sub>5</sub>	kg/ha K <sub>2</sub> O	l/ha
10	2	5	56
20	5	10	111
30	7	15	167
40	9	20	222
50	12	25	278
60	14	30	333
70	16	35	389
80	19	40	444
90	21	45	500
100	23	50	556
110	26	55	611
120	28	60	667
130	30	65	722
140	33	70	778
150	35	75	833
160	37	80	889
170	40	85	944
180	42	90	1000
190	44	95	1056
200	47	100	1111
Specific Gravity (SG): 1.20			

OMEX 14-7-7			
kg/ha N	kg/ha P <sub>2</sub> O <sub>5</sub>	kg/ha K <sub>2</sub> O	l/ha
10	5	5	58
20	10	10	115
30	15	15	173
40	20	20	230
50	25	25	288
60	30	30	346
70	35	35	403
80	40	40	461
90	45	45	518
100	50	50	576
110	55	55	634
120	60	60	691
130	65	65	749
140	70	70	806
150	75	75	864
160	80	80	922
170	85	85	979
180	90	90	1037
190	95	95	1094
200	100	100	1152
Specific Gravity (SG): 1.24			

OMEX 10-5-9			
kg/ha N	kg/ha P <sub>2</sub> O <sub>5</sub>	kg/ha K <sub>2</sub> O	l/ha
10	5	9	83
20	10	18	167
30	15	27	250
40	20	36	333
50	25	45	417
60	30	54	500
70	35	63	583
80	40	72	667
90	45	81	750
100	50	90	833
110	55	99	917
120	60	108	1000
130	65	117	1083
140	70	126	1167
150	75	135	1250
160	80	144	1333
170	85	153	1417
180	90	162	1500
190	95	171	1583
200	100	180	1667
Specific Gravity (SG): 1.20			

OMEX 10-0-10			
kg/ha N	kg/ha P <sub>2</sub> O <sub>5</sub>	kg/ha K <sub>2</sub> O	l/ha
10	0	10	83
20	0	20	167
30	0	30	250
40	0	40	333
50	0	50	417
60	0	60	500
70	0	70	583
80	0	80	667
90	0	90	750
100	0	100	833
110	0	110	917
120	0	120	1000
130	0	130	1083
140	0	140	1167
150	0	150	1250
160	0	160	1333
170	0	170	1417
180	0	180	1500
190	0	190	1583
200	0	200	1667
Specific Gravity (SG): 1.20			

OMEX 8-8-8			
kg/ha N	kg/ha P <sub>2</sub> O <sub>5</sub>	kg/ha K <sub>2</sub> O	l/ha
10	10	10	102
20	20	20	203
30	30	30	305
40	40	40	407
50	50	50	508
60	60	60	610
70	70	70	711
80	80	80	813
90	90	90	915
100	100	100	1016
110	110	110	1118
120	120	120	1220
130	130	130	1321
140	140	140	1423
150	150	150	1524
160	160	160	1626
170	170	170	1728
180	180	180	1829
190	190	190	1931
200	200	200	2033
Specific Gravity (SG): 1.25			

OMEX 9-3-10			
kg/ha N	kg/ha P <sub>2</sub> O <sub>5</sub>	kg/ha K <sub>2</sub> O	l/ha
10	3	11	93
20	7	22	187
30	10	33	280
40	13	44	373
50	17	56	467
60	20	67	560
70	23	78	654
80	27	89	747
90	30	100	840
100	33	111	934
110	37	122	1027
120	40	133	1120
130	43	144	1214
140	47	156	1307
150	50	167	1401
160	53	178	1494
170	57	189	1587
180	60	200	1681
190	63	211	1774
200	67	222	1867
Specific Gravity (SG): 1.19			

OMEX 7-20-0		
kg/ha N	kg/ha P <sub>2</sub> O <sub>5</sub>	l/ha
2	5	20
4	10	41
5	15	61
7	20	82
9	25	102
11	30	123
12	35	143
14	40	164
16	45	184
18	50	205
19	55	225
21	60	246
23	65	266
25	70	287
26	75	307
28	80	328
30	85	348
32	90	369
33	95	389
35	100	410
Specific Gravity (SG): 1.22		

OMEX 7-7-10			
kg/ha N	kg/ha P <sub>2</sub> O <sub>5</sub>	kg/ha K <sub>2</sub> O	l/ha
10	10	14	119
20	20	29	238
30	30	43	357
40	40	57	476
50	50	71	595
60	60	86	714
70	70	100	833
80	80	114	952
90	90	129	1071
100	100	143	1190
110	110	157	1310
120	120	171	1429
130	130	186	1548
140	140	200	1667
150	150	214	1786
160	160	229	1905
170	170	243	2024
180	180	257	2143
190	190	271	2262
200	200	286	2381
Specific Gravity (SG): 1.24			

OMEX 3.5-10-10			
kg/ha N	kg/ha P <sub>2</sub> O <sub>5</sub>	kg/ha K <sub>2</sub> O	l/ha
4	10	10	81
7	20	20	161
11	30	30	242
14	40	40	323
18	50	50	403
21	60	60	484
25	70	70	565
28	80	80	645
32	90	90	726
35	100	100	806
39	110	110	887
42	120	120	968
46	130	130	1048
49	140	140	1129
53	150	150	1210
56	160	160	1290
60	170	170	1371
63	180	180	1452
67	190	190	1532
70	200	200	1613
Specific Gravity (SG): 1.24			

OMEX 14-14-0		
kg/ha N	kg/ha P <sub>2</sub> O <sub>5</sub>	l/ha
5	5	30
10	10	59
15	15	89
20	20	118
25	25	148
30	30	177
35	35	207
40	40	236
45	45	266
50	50	295
55	55	325
60	60	354
65	65	384
70	70	413
75	75	443
80	80	472
85	85	502
90	90	531
95	95	561
100	100	590
Specific Gravity (SG): 1.21		

OMEX 17-8-0		
kg/ha N	kg/ha P <sub>2</sub> O <sub>5</sub>	l/ha
10	5	49
20	9	98
30	14	147
40	19	196
50	24	245
60	28	294
70	33	343
80	38	392
90	42	441
100	47	490
110	52	539
120	56	588
130	61	637
140	66	686
150	71	735
160	75	784
170	80	833
180	85	882
190	89	931
200	94	980
Specific Gravity (SG): 1.20		

# Application Charts – Nitroflo range

## Application Chart Nitroflo 30: 30%

kg/ha N	units/ac N	l/ha
25	20	64
30	24	77
35	28	90
40	32	103
45	36	115
50	40	128
55	44	141
60	48	154
65	52	167
70	56	180
75	60	192
80	64	205
85	68	218
90	72	231
95	76	244
100	80	256
105	84	269
110	88	282
115	92	295
120	96	308
125	100	321
130	104	333
135	108	346
140	112	359
145	116	372
150	120	385
155	124	397
160	128	410
165	132	423
170	136	436
175	140	449
180	144	462
185	148	474

Specific Gravity (SG): 1.30

Please note that the SG varies slightly with temperature

Apply with appropriate nozzles

Avoid application during very windy weather or when the leaf is damp

Do not apply on a rime frost or following severe frost

## Application Chart Nitroflo 28+S: 28% N+2.5% SO<sub>3</sub>

kg/ha N	units/ac N	kg/ha SO <sub>3</sub>	units/ac SO <sub>3</sub>	l/ha
25	20	2	2	69
30	24	3	2	83
35	28	3	3	97
40	32	4	3	111
45	36	4	3	125
50	40	4	4	138
55	44	5	4	152
60	48	5	4	166
65	52	6	5	180
70	56	6	5	194
75	60	7	5	208
80	64	7	6	221
85	68	8	6	235
90	72	8	6	249
95	76	8	7	263
100	80	9	7	277
105	84	9	8	291
110	88	10	8	305
115	92	10	8	318
120	96	11	9	332
125	100	11	9	346
130	104	12	9	360
135	108	12	10	374
140	112	13	10	388
145	116	13	10	401
150	120	13	11	415
155	124	14	11	429
160	128	14	11	443
165	132	15	12	457
170	136	15	12	471
175	140	16	13	484
180	144	16	13	498
185	148	17	13	512

Specific Gravity (SG): 1.29

Please note that the SG varies slightly with temperature

Apply with appropriate nozzles

Avoid application during very windy weather or when the leaf is damp

Do not apply on a rime frost or following severe frost

## Application Chart Nitroflo 26+S: 26% N+5% SO<sub>3</sub>

kg/ha N	units/ac N	kg/ha SO <sub>3</sub>	units/ac SO <sub>3</sub>	l/ha
25	20	5	4	75
30	24	6	5	90
35	28	7	6	105
40	32	8	6	120
45	36	9	7	135
50	40	10	8	150
55	44	11	9	165
60	48	12	10	180
65	52	13	10	195
70	56	14	11	210
75	60	14	11	225
80	64	15	12	240
85	68	16	13	255
90	72	17	14	270
95	76	18	14	286
100	80	19	15	301
105	84	20	16	316
110	88	21	17	331
115	92	22	18	346
120	96	23	18	361
125	100	24	19	376
130	104	25	20	391
135	108	26	21	406
140	112	27	22	421
145	116	28	22	436
150	120	29	23	451
155	124	30	24	466
160	128	31	25	481
165	132	32	26	496
170	136	33	26	511
175	140	34	27	526
180	144	35	28	541
185	148	36	29	556

Specific Gravity (SG): 1.28

Please note that the SG varies slightly with temperature

Apply with appropriate nozzles

Avoid application during very windy weather or when the leaf is damp

Do not apply on a rime frost or following severe frost

## Application Chart Nitroflo 24+S: 24% N+7.5% SO<sub>3</sub>

kg/ha N	units/ac N	kg/ha SO <sub>3</sub>	units/ac SO <sub>3</sub>	l/ha
25	20	8	6	82
30	24	9	8	98
35	28	11	9	115
40	32	13	10	131
45	36	14	11	148
50	40	16	13	164
55	44	17	14	180
60	48	19	15	197
65	52	20	16	213
70	56	22	18	230
75	60	23	19	246
80	64	25	20	262
85	68	27	21	279
90	72	28	23	295
95	76	30	24	312
100	80	31	25	328
105	84	33	26	344
110	88	34	28	361
115	92	36	29	377
120	96	38	30	394
125	100	39	31	410
130	104	41	33	427
135	108	42	34	443
140	112	44	35	460
145	116	45	36	476
150	120	47	38	492
155	124	48	39	509
160	128	50	40	525
165	132	52	41	542
170	136	53	43	558
175	140	55	44	575
180	144	56	45	591
185	148	58	46	607

Specific Gravity (SG): 1.27

Please note that the SG varies slightly with temperature

Apply with appropriate nozzles

Avoid application during very windy weather or when the leaf is damp

Do not apply on a rime frost or following severe frost

## Application Chart Nitroflo 22+S: 22% N+10% SO<sub>3</sub>

kg/ha N	units/ac N	kg/ha SO <sub>3</sub>	units/ac SO <sub>3</sub>	l/ha
25	20	11	9	91
30	24	14	11	109
35	28	16	13	129
40	32	18	15	145
45	36	20	16	163
50	40	23	18	181
55	44	25	20	199
60	48	27	22	217
65	52	30	24	235
70	56	32	26	253
75	60	34	27	271
80	64	36	29	289
85	68	39	31	307
90	72	41	33	325
95	76	43	35	343
100	80	45	36	361
105	84	48	38	379
110	88	50	40	397
115	92	52	42	415
120	96	55	44	433
125	100	57	46	451
130	104	59	47	469
135	108	61	49	487
140	112	64	51	505
145	116	66	53	523
150	120	68	55	541
155	124	70	56	559
160	128	73	58	578
165	132	75	60	596
170	136	77	62	614
175	140	80	64	632
180	144	82	66	650
185	148	84	67	668

Specific Gravity (SG): 1.26

Please note that the SG varies slightly with temperature

Apply with appropriate nozzles

Avoid application during very windy weather or when the leaf is damp

Do not apply on a rime frost or following severe frost

## Application Chart Nitroflo 20+S: 20% N+12.5% SO<sub>3</sub>

kg/ha N	units/ac N	kg/ha SO <sub>3</sub>	units/ac SO <sub>3</sub>	l/ha
25	20	16	13	100
30	24	19	15	120
35	28	22	18	140
40	32	25	20	160
45	36	28	23	180
50	40	31	25	200
55	44	34	28	220
60	48	38	30	240
65	52	41	33	260
70	56	44	35	280
75	60	47	38	300
80	64	50	40	320
85	68	53	43	340
90	72	56	45	360
95	76	59	48	380
100	80	63	50	400
105	84	66	53	420
110	88	69	55	440
115	92	72	58	460
120	96	75	60	480
125	100	78	63	500
130	104	81	65	520
135	108	84	68	540
140	112	88	70	560
145	116	91	73	580
150	120	94	75	600
155	124	97	78	620
160	128	100	80	640
165	132	103	83	660
170	136	106	85	680
175	140	109	88	700
180	144	113	90	720
185	148	116	93	740

Specific Gravity (SG): 1.25

Please note that the SG varies slightly with temperature

Apply with appropriate nozzles

Avoid application during very windy weather or when the leaf is damp

Do not apply on a rime frost or following severe frost

## Application Chart Nitroflo 15+S: 15% N+15% SO<sub>3</sub>

kg/ha N	units/ac N	kg/ha SO <sub>3</sub>	units/ac SO <sub>3</sub>	l/ha
25	20	25	20	137
30	24	30	24	164
35	28	35	28	191
40	32	40	32	219
45	36	45	36	246
50	40	50	40	273
55	44	55	44	301
60	48	60	48	328
65	52	65	52	355
70	56	70	56	383
75	60	75	60	410
80	64	80	64	437
85	68	85	68	465
90	72	90	72	492
95	76	95	76	519
100	80	100	80	547
105	84	105	84	574
110	88	110	88	601
115	92	115	92	629
120	96	120	96	656
125	100	125	100	683
130	104	130	104	711
135	108	135	108	738
140	112	140	112	765
145	116	145	116	793
150	120	150	120	820
155	124	155	124	847
160	128	160	128	875
165	132	165	132	902
170	136	170	136	929
175	140	175	140	957
180	144	180	144	984
185	148	185	148	1011

Specific Gravity (SG): 1.22

Please note that the SG varies slightly with temperature

Apply with appropriate nozzles

Avoid application during very windy weather or when the leaf is damp

Do not apply on a rime frost or following severe frost



## Go Liquid

with the UK's largest independent manufacturers of **liquid fertilisers**. Offering 24/7 dedicated support to **UK grassland farmers**, with national coverage and local service.

**CONTACT US TODAY**

**Call 01526 396000**  
**Visit [www.omex.com](http://www.omex.com)**

## Application Bars & Nozzles

A range of streamer caps and streamer bars are available for applying liquid nitrogen to emerged crops. They vary from simple caps to advanced, self-contained streamer bars. Check with suppliers for latest prices

### **Spraying Systems (TeeJet) Jet Stream**

A simple cap producing 3 divergent vertical streams. Rate is altered by varying pressure and metering disc.

### **Lechler FD Fertiliser Nozzle**

A novel, low pressure deflector nozzle, producing a horizontal fan pattern of coarse droplets with no 'fines'. Even distribution (no streams) and flexible application rates (operate at pressure of 2-4 bar).

### **Spraying Systems (TeeJet) Stream Jet SJ7**

A 7-stream jet which produces a 'rain-effect' pattern across the boom. A recent change is that the jet body is now integral with metering disc, so different coloured bodies are used for different rates; no need to change metering discs.

### **Hypro Fastcap® ESI**

6-stream cap, with streams directed down onto crop, claimed to produce a low-atomisation stream of nitrogen. Supplied as nozzle+metering orifice with two nozzles required to cover most application rates. Supplied in a box of 6 nozzles.

### **Hardi Quintastream**

Produce 5 semi-vertical streams, each stream engineered to create an accurate and even application on the crop. They come with Hardi jet bodies but can be adapted to Teejet bodies by removing the nozzle insert from the body and mounting in a Teejet cap. Rate altered by changing restrictor with tool that comes with jet. Different coloured bodies for different rates.

### **Umbrella Jets**

Produce a 'rain-effect' of low pressure, large droplets from a semi-circle of outlets at the base of an extended nozzle body giving a wide range of application rates simply by varying pressure.

### **CFM Streamer Bar**

A channel-fed bar, with 4 vertical streams per bar. Rate is altered by varying pressure and selecting restrictor that is simple to change.

### **BFS Streamer Bar**

A channel-fed bar, with 4 vertical streams from each ½m spacing bar. Application rate is altered by varying pressure and rotating a wheel in the body of the bar to required metering orifice.

### **OMEX Streambar**

The OMEX Streambar produces 4 vertical streams from each bar, ensuring even coverage across the full boom regardless of the bars height above the ground. Each stream is fed individually to ensure the output from all four streams are identical even with the bar tilted. A wide range of application rates can be achieved and are changed using the built in slider. (see page 29)

### **Spraying Systems (TeeJet) SJ7-VR**

A half umbrella pattern with 7 streams and a variable rate restrictor for use with flow-based controllers. Restrictor is based on reliable EPDM elastomer and allows rate to vary with speed or variable rate map, without the need to change jets.

### **Spraying Systems (TeeJet) SJ3-VR**

Three divergent streams with a variable rate restrictor, only for use with flow based controllers. No need to change metering discs or settings and restrictor provides constant resistance to allow rates to be changed on the move.

### **Pentair (Hypro) ESI variable rate nozzle**

Variable restrictor based on integral variable orifice. Produces 6 divergent streams from novel unique nozzle body. Correct pattern overlap at 3 boom heights provides flexibility. Single nozzle covers wide range of application rates and allows rate to be changed in operation, ideal for variable rate application.

### **AccuRate Dribblebar**

Precision rate control with stainless steel regulator. Applies for 90-2200 l/ha with minimal setting. Minimal drip when switched off. Ideal for use on second spray line.

**Please check with suppliers for latest prices**

## OMEX Streambar



**Streamer bars are the most efficient and accurate method of applying nitrogen to crops and the OMEX Streambar is one of the most convenient and cost-effective bars available.**

Streambars apply liquid nitrogen and sulphur in a vertical stream, allowing nitrogen to be applied at the full rate right up to the field boundary. The vertical spray pattern means boom height is not restricted, allowing booms to run low in windy

conditions and ensuring that the pattern is not affected by undulating ground. Each of the four outlets on the bar is fed independently from the restrictor, so the rate remains completely consistent across the bar on sloping ground.



### Quality Design

The OMEX Streambar is manufactured in the UK and the compact design reduces the risk of breakage if the boom makes contact with the crop, ground or hedges. The bars have linking hooks to allow them to be connected if required, to prevent them twisting out of line. The bars are fully serviceable with three O-ring seals being the only wearing parts.

### Droplet Size

The stream produced by the bar breaks into individual, large droplets soon after leaving the bar and the large heavy droplets are key to reducing the risk of scorch.

### Application Tables

Application rates are conveniently altered with a sliding restrictor, allowing a full wide range of application rates to be achieved without changing nozzle bodies or restrictors and keeping the operator clean and free of contact with fertiliser.

Simple to use application charts are supplied with the Streambars, detailing either the litres/hectare or kg/ha nitrogen applied - removing the need for a separate product application chart. As an office-based support, a simple calculator is also available to run on a PC.



# Storage Tank Schemes

## Rental Scheme for 30m<sup>3</sup>, 40m<sup>3</sup> and 50m<sup>3</sup> GRP

	30m <sup>3</sup>	40m <sup>3</sup>	50m <sup>3</sup>
<b>Farmer Qualification</b>			
New customer to OMEX Nitroflo	✓	✓	✓
Minimum number of tonnes of Nitroflo per annual	75	100	120
<b>OMEX to Supply</b>			
One tank, complete with fully lockable filling valve, inspection and cleaning access hatch, sight gauge on steel tanks, GRP fixing ties and locks.	30,000 litre (approx 37 tonne capacity)	40,000 litre (approx 50 tonne capacity)	50,000 litre (approx 60 tonne capacity)
Tank delivered and off loaded on farm	✓	✓	✓
Drawings showing dimensions of tank plus foundations if required	✓	✓	✓
<b>The Scheme</b>			
Year one free of charge	✓	✓	✓
An annual rental (payable in advance)	£300	£500	£600
A retrospective rebate of £2.00 per tonne will be paid per annum on Nitroflo range only	Up to the value of £300	Up to the value of £500	Up to the value of £600
<b>Farmer to Supply</b>			
An accessible site for tank	✓	✓	✓
Concrete foundation and bund for tank	✓	✓	✓
Roofing felt layer beneath tank	✓	✓	✓
Bolts and fixing	✓	✓	✓
Planning permission (if required)	✓	✓	✓

All prices exclude VAT



OMEX Agriculture reserves the right to uplift the tank if annual offtake falls below 50 tonnes for the 30m<sup>3</sup> and 40m<sup>3</sup>, and 100 tonnes for the 50m<sup>3</sup> or if rental is unpaid. The farmer is responsible for paying crane hire for the removal of the tank.

# Tank Base & Bund Dimensions

## For 30m<sup>3</sup> GRP Tank

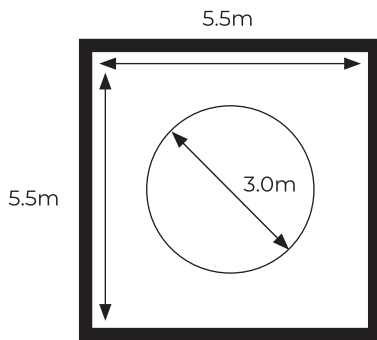

Example

Tank Height: 4.65m

Bunds require a capacity of at least 33 cubic metres

Examples of dimensions

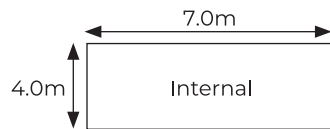

1.2m high

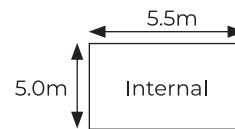

1.2m high

## For 40m<sup>3</sup> GRP Tank

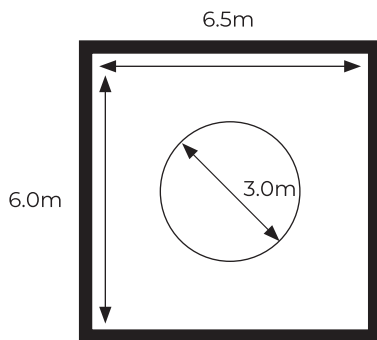

Example

Tank Height: 6.02m

Bunds require a capacity of at least 44 cubic metres

Examples of dimensions

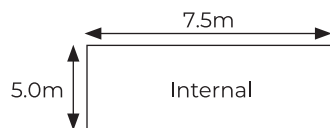

1.2m high

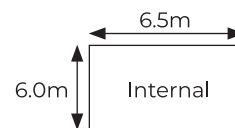

1.2m high

## For 50m<sup>3</sup> GRP Tank

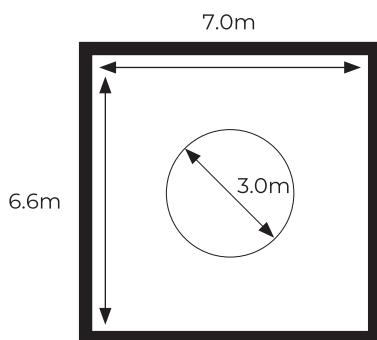

Example

Tank Height: 7.4m

Bunds require a capacity of at least 55 cubic metres

Examples of dimensions

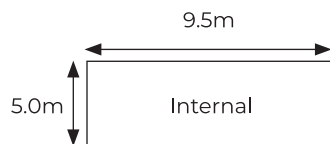

1.2m high

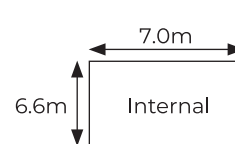

1.2m high

## Tank Base



- The thickness will depend on the ground conditions
- It should be a flat, smooth reinforced concrete slab
- Minimum 200mm thick

# PROTECTING THE ENVIRONMENT

## THE ESSENTIALS FOR STORING SOLID AND LIQUID FERTILISERS



### Losses from stored fertiliser may:

- seriously damage water quality
- lead to substantial fines for pollution

Today, farm storage of fertilisers is covered by Codes of Practice to prevent water pollution. Unless farmers adhere to these codes, enforcement action could be taken or new legislation imposed.<sup>(1)</sup> This leaflet summaries your obligations under the Codes.

Adhering to the codes is not daunting. Often a little time spent on inspection, planning and a small investment in maintenance will avoid large fines, upset neighbours and loss of reputation.

### Footnote

1. The Anti-Pollution Works Regulations 1999, [www.legislation.gov.uk](http://www.legislation.gov.uk) or from The Stationery Office, T: 0870 6005522
2. Code of Practice for the Prevention of Water Pollution from the Storage and Handling of Fluid and Solid Fertilisers – free from Agricultural Industries Confederation, T: 01733 385230 or from website [www.agindustries.org.uk](http://www.agindustries.org.uk)
3. The Dangerous Substances (Notification and Marking of Sites) Regulations 1990, [www.legislation.gov.uk](http://www.legislation.gov.uk), The Stationery Office, T: 0870 6005522

### GENERAL GUIDELINES FOR ALL STORES

- Site all stores as far from watercourses or surface water drains as possible – never less than 10m.
- Site at least 50m from any well, borehole, or aquifer outcrop where risk of groundwater contamination is high.
- Provide secondary containment for storage where contamination risk is high.
- Ensure good well constructed vehicular access.
- Keep an inventory of fertiliser stored – type, volume, delivery.
- Make all storage as secure as possible with consideration given to lighting and fencing.
- Site all stores away from public access to minimise interference or vandalism.
- Ensure operators are trained in use and emergency procedures.
- Obtain Code of Practice for the Prevention of Water Pollution from the Storage and Handling of Fluid and Solid Fertilisers<sup>(2)</sup> – the definitive reference.

### SOLID FERTILISER STORAGE

Solid fertilisers, provided the storage area is well-sited and constructed, are a low risk of watercourses. The main risk occurs in the event of a fire, if contaminated firewater escapes.

#### PERMANENT STORES

##### Siting

- Locate away from heat sources to minimise fire risk.
- Site away from combustible materials eg fuels, oils, hay, straw and wood.
- Ensure sites are level and not prone to flooding.
- Ensure indoor storage is on smooth, firm, dry, impermeable concrete floors.
- Avoid prolonged outdoor storage but where unavoidable ensure it is protected from rain and sunlight with shrink wrapping and/or sheeting.
- Keep storage areas clean and rodent free.
- Handle all bags with care eg fit pipes on sharp forklift tines.

- Re-bag damaged bags immediately.
- Sweep up spillage and dispose of sweepings in slurry pits or spread thinly on growing crops.
- Do not use sawdust as an absorbent.
- Notify the Fire Authority and Health & Safety Executive if 25 tonnes, or more, of ammonium nitrate is stored at any one time.<sup>(3)</sup>
- Develop contingency plans to contain contaminated firewater and prevent entry to drains or watercourses.

#### TEMPORARY FIELD STORAGE

- Do not store within 10m of ditch, watercourse or land drains.
- Return unused bags to a permanent store as soon as possible.

## FLUID FERTILISER STORAGE

Farmers share a duty of care for siting, use and maintenance, even when fertiliser suppliers provide tanks.

### Using tanks

- Ensure tanks, pipework and valves are fit for purpose, ie resistant to corrosion.
- Ensure all tank fittings are tamper-proof. Lock all valves shut when not in use.
- Ensure delivery companies are aware of emergency procedures.
- Ensure tank, pipework and valves are in good condition before deliveries are made.
- Check tank has sufficient capacity before delivery.
- Avoid overfilling.

### Maintaining tanks

- Have tanks, pipework and valves inspected internally and externally, for damage and corrosion at least annually by a suitably qualified technician.
- Carry out any necessary remedial work immediately.
- Undertake additional checks at

the start of the season and when deliveries are made to and from the tank<sup>(4)</sup>. If in doubt do not use the tank or bowser.

- Drain down and flush through all pipework at the end of each season.
- Keep a maintenance record.

### PERMANENT STORAGE

- Conduct an environmental risk assessment<sup>(5)</sup>. Advice is available from the Environment Agency.
- Construct secondary containment where environment assessment shows high risk. Use of reinforced masonry or concrete is recommended and provision should be made for at least 110% of tank capacity. Properly designed and constructed earth embankments may be an acceptable alternative. All pipes, valves and sight gauges should be within the containment area. (NB As a last resort, the Environment Agency can issue a works notice requiring secondary containment in high risk locations<sup>(1)</sup>).
- Tanks must be on a solid, stable concrete base of footing to take the full tank weight.

- Consider additional stabilisation against high winds for GRP tanks.

### BOWSERS AND MOBILE TANKS

- Temporary storage can pose a significant hazard to watercourses. Thus suitable siting is crucial before filling or dispensing. Transport around the farm needs careful consideration. Roadways and tracks must be able to withstand fully laden bowsters passing over or being parked on them.
- Ensure bowsters and all fittings are fit for purpose and protected from corrosion.
- Ensure bowsters are set down on level, solid ground before delivery is made.
- Provide sufficient support beneath parking legs to carry loaded weight without it sinking into the ground or becoming unstable.
- Ensure all hatches and manholes form a watertight seal when closed.
- Do not move laden bowster unless all hatches, lids and valves are closed and locked.
- Open hatches slightly, when emptying bowsters, to avoid a vacuum which could cause the tank to crumple and collapse.



## DEALING WITH SPILLAGES, EMERGENCY PROCEDURES AND STAFF TRAINING

### DEALING WITH SPILLAGES

- Contain any spillage wherever possible.
- Use inert absorbent materials, eg sand or earth, for liquid spills (not sawdust).
- Block gullies, drainage systems or other routes to watercourses.
- Do NOT hose down a spillage.

### EMERGENCY PROCEDURES

- Identify routes to vulnerable watercourses and groundwater on your farm.
- Establish and test emergency procedures.
- Devise spillage, emergency and firewater procedures to provide containment areas near tanks, bowsters or stores.

### Footnote

(4) Instructions for inspecting condition of fluid fertiliser tanks (free) – Agricultural Industries Confederation 01733 385230 or from website: [www.agindustries.org.uk](http://www.agindustries.org.uk).

(5) Risk assessment guide on siting storage facilities (free) – Agricultural Industries Confederation 01733 385230 or from website: [www.agindustries.org.uk](http://www.agindustries.org.uk).

- Consider blocking drains and damming watercourses as well as providing drain-blocking mats or drain bungs.
- Use leak-sealing putty on tanks and pipework for temporary repair.
- Inform and train everyone likely to become involved in dealing with a spillage or fire.
- Identify who to contact in the event of a spillage, loss or fire.
- Ensure all have access to important telephone numbers, eg local Environment Agency Office, fertiliser supplier and emergency services.
- Report any significant spillage to the farmer, the supplier and Environment Agency.

## FURTHER INFORMATION

Code of good agricultural practice; Protecting our Water, Soil and Air' Download free from [www.defra.gov.uk/publications](http://www.defra.gov.uk/publications) or hard copy (£12.50) from [www.tso.co.uk](http://www.tso.co.uk)

### The Environment Agency

Pollution Prevention Guidance Notes:

PPG2 – *Above ground oil storage tanks* – for containment wall information

PPG18 – *Pollution prevention measures for the control of spillages and fire fighting runoff* – for more detailed information about storing chemicals.

*Policy and practice for the protection of groundwater*

Ground Water Vulnerability Maps

Working in partnership to prevent pollution

Environment Agency – 24 hour Emergency Hotline 0800 807060

For non-emergency general advice, phone 03708 506506



Environment  
Agency



# CODE OF PRACTICE FOR THE PREVENTION OF WATER POLLUTION FROM THE STORAGE AND HANDLING OF FLUID FERTILISERS

## PART 3 - USERS

2021



PRODUCED IN CONSULTATION WITH



## PART 3 – USERS

**This Code of Practice for the Prevention of Water Pollution from the Storage and Handling of Fluid Fertilisers (hereafter referred to as the 'Code') is in three parts:**

**PART 1 – SUPPLIERS**

**PART 2 – TANKER DRIVERS**

**PART 3 – USERS**

The Code is published and recommended by the Agricultural Industries Confederation (AIC). The information is given in good faith and does not imply the acceptance of any legal liability or responsibility whatsoever, by AIC or by individual AIC members for the consequences of its use or misuse or in any particular circumstances.

## PREFACE

**As a user of fluid fertilisers**, you are handling materials which, if spilled in quantity, can be very damaging to the water environment. This Code of Practice has been drawn up to help you to reduce the risk of causing water pollution as a result of losing fluid fertiliser during storage or handling at the farm.

There is clear economic benefit to the user in reducing losses of nutrients to the wider environment, whether from accidental spillage, poor management practices or vandalism. Any of these could result in water pollution which could have serious consequences, both legal and financial. The costs of pollution clean-up and any fish restocking for example would be charged to the polluter or relevant parties. With some forethought and planning for emergencies you should be able to answer the question: 'What would be the consequences of a major spillage of fluid fertiliser at your site?' You must know your site and the surrounding drainage system and what to do and how to react to an accident or emergency so as to minimise the chances of causing pollution.

Preplanning is essential so that you avoid having to deal with a real incident unprepared. Pollution of surface waters by fertiliser is a serious matter but at least it is possible to monitor it directly and carry out remedial action, albeit at some cost. If a major spillage of fluid fertiliser onto the ground is allowed to soak away, any groundwater contamination will be impossible to monitor except by costly techniques and may be impossible to remedy. Pollution of groundwater is potentially very serious because this water can be used

extensively for public drinking water supplies and for industrial and agricultural use. The environment agencies in England, Wales, Scotland and Northern Ireland have identified all groundwater resources and have specific policies for the protection of sources through the control of activities and development in close proximity to source extraction boreholes. Groundwater resources and extraction boreholes are valuable and expensive assets. It is essential that those storing and handling fluid fertilisers are aware of the vulnerability of nearby groundwater sources so that this can be taken into account when siting storage facilities and drawing up emergency plans. The objective must be to ensure that pollution is prevented and that in the event of a major spillage, fluid fertiliser is not allowed to soak through the soil directly, or by way of drains and soak-aways in these vulnerable areas.

If you require further more specific information about the sensitivity of your site with respect to the water environment the environment agencies are always pleased to offer advice. AIC also publishes a **Code of Practice for the Prevention of Water Pollution from the Storage and Handling of Solid Fertilisers**.



## PART 3 – USERS

### 3.1 INTRODUCTION

**3.1.1** This 'Code of Practice for the Prevention of Water Pollution from the Storage and Handling of Fluid Fertilisers, (Part 3, [Users])' is a practical guide to help users avoid loss or spillage of **fluid fertiliser** which could cause water pollution.

**3.1.2** This Code is without prejudice to any legal obligations safety requirements or other codes of practice.

**3.1.3** Following this Code is not a defence against a charge of causing pollution, although it should reduce the chance of pollution occurring and will help provide proof of due diligence and good working practice.

**3.1.4** Users should ensure that they carry adequate insurance cover against liability for pollution.

**3.1.5** This Code does not cover guidance for the appropriate usage of **fluid fertiliser**. Reference should be made to Protecting Our Water, Soil and Air: a Code of Good Agricultural Practice (Defra - England), Prevention of Environmental Pollution from Agricultural Activity (Scottish Government - Scotland), and the Code of Good Agricultural Practice (DARD – Northern Ireland), and also to published fertiliser recommendations. See Fertiliser Manual (Appendix 1).

**3.1.6** This Code has been drawn up in consultation with the Environment Agency England, Natural Resources Wales, the Scottish Environment Protection Agency and the Northern Ireland Environment Agency. (Appendix 1)

### 3.2 DEFINITIONS

**For the purposes of this Code, the term:**

**3.2.1** 'User' shall mean the farmer, grower, application contractor and organisation or individual responsible for the end-use of fluid fertilisers. Delivery and transportation on the public highway is covered in part 2 of this Code.

**3.2.2** 'Supplier' shall refer to the manufacturer, importer, distributor, merchant, haulier or other organisation or individual who supplies the **user** with **fluid fertiliser**.

**3.2.3** 'Tanker Driver' shall mean the driver of any vehicle designed to transport and deliver liquid fertilisers in bulk or semi bulk Intermediate Bulk Containers (IBCs)

**3.2.4** 'Fluid Fertiliser' shall include all solution fertilisers (otherwise known a liquid fertilisers), suspension fertilisers and aqueous ammonia solutions not exceeding 34% ammonia Organic-based fluids containing plant nutrients such as farm slurries, AD Digestate, sewage sludges or other effluents are expressly excluded.

**3.2.5** 'Bund' shall mean a strongly constructed secondary containment with impermeable walls and floor.

**3.2.6** 'Watercourse' shall include all surface water whether coastal water, estuary, lake, pond, river, stream, canal and field ditch, (even when dry), unless it is a containment ditch.

**3.2.7** 'Groundwater' shall be defined as water which is below the surface of the ground in the saturation zone and in direct contact with the ground and/or water held in underground rock formations (aquifers). For the purposes of this Code it is considered that pollution of **Groundwater** could result from incidents occurring where such aquifers outcrop at or near the soil surface, or occurring within 50 metres of a water abstraction borehole, or where no protection of the underlying water exists e.g. where there are soakaways, swallow holes or quarries.

**3.2.8** 'Major Spillage' shall refer to a spillage which cannot be controlled and/or which involves significant loss of the spillage causing pollution of a **watercourse** or of **groundwater**.

### 3.3 GENERAL PRINCIPLES

**3.3.1** Fluid fertilisers can be applied to a field very accurately, thereby avoiding unwanted and potentially damaging applications to field margins, hedge bottoms or ditches. As with all nutrient sources, including solid fertilisers and organic manures and wastes, care must be taken with their storage, transfer and transportation. Detailed guidelines are given but attention is drawn to six main points:

- Fixed or mobile stores must be sited with care,
- Any spillage which occurs must be properly dealt with to avoid pollution,

<ul style="list-style-type: none"> <li>• Stores, valves and pipework must be properly maintained and inspected, and records kept,</li> <li>• Bowsers or tankers, before being moved, must have their hatches/ lids securely closed.</li> <li>• Valves must be secured so that they can only be opened by authorised personnel,</li> <li>• There must be a spillage contingency plan. Know what to do in an emergency.</li> </ul>	
<p><b>3.3.2</b> All procedures, equipment and installations should be designed to avoid any spillage of <b>fluid fertilisers</b>.</p>	<p><b>3.4.4</b> Existing sites, and preferably all new sites, should be in areas where groundwater vulnerability is low and not in highly sensitive areas. Sensitive areas are in the proximity of boreholes, wells, springs, aquifer outcrops, soak-aways, swallow holes, quarries or within 50 metres of abstraction for potable supply. For further guidance on groundwater protection contact the appropriate environment agency (Appendix 1) or refer to the Environment Agency web-based resource 'What's in your backyard' (See Appendix 1).</p>
<p><b>3.3.3</b> In the event of such spillage, appropriate procedures and resources should be in-place to prevent the pollution of <b>watercourses</b> or <b>groundwater</b>.</p>	<p><b>3.4.5</b> Consideration should be given as to where any spilled <b>fluid fertiliser</b> would flow in the event of an accident during loading or unloading, or if the store were to develop a leak or be vandalised. Fire-fighting run-off also presents a risk. The total potential spillage must be capable of containment in an impermeable area. Where such areas are on the outcrop of an aquifer, the need to protect <b>groundwater</b> must be considered.</p>
<p><b>3.3.4</b> Frequent inspections and regular maintenance should be made of all pipework, valves, tanks, bowsers, lagoons, hard-standing, bunds (if provided) and security systems to minimise the risk of accidental leakage or failure. Records should be kept of this maintenance and inspection.</p>	<p><b>3.4.6</b> The potential route of any escaping <b>fluid fertiliser</b> should be channeled to a suitable impermeable area by means of permanent soil banks and/or kerbs where necessary. Care should be taken to prevent any spilled <b>fluid fertiliser</b> from running down a road and thus into drains. Soil is a better and more absorbent temporary barrier than sand.</p>
<p><b>3.3.5</b> New and replacement installations should have permanent bunding or an appropriate secondary containment system installed.</p>	
<p><b>3.3.6</b> The servicing and filling of third party owned tanks is not recommended</p>	
<p><b>3.4 SITING OF FLUID FERTILISER STORAGE TANKS, LAGOONS AND BOWSERS</b></p>	
<p><b>3.4.1</b> Suitable siting of storage tanks, lagoons and bowsers is critical to avoid potential pollution of <b>watercourses</b> or <b>groundwater</b> in the event of any spillage.</p>	<p><b>3.4.7</b> Care needs to be taken in every case with the appropriate siting of tankers, mobile tankers or bowsers. Tankers, mobile tanks and bowsers should all be sited so as to minimise the risk of any spillage of <b>fluid fertiliser</b> entering a <b>watercourse</b> or <b>groundwater</b>, even though such siting may be only temporary.</p>
<p><b>3.4.2</b> Good, well-constructed vehicular access for large delivery and off-take vehicles is essential. An impermeable hard-standing should be provided at the point of delivery to enable any minor spillage to be contained.</p>	<p><b>3.4.8</b> No <b>fluid fertiliser</b> shall be received into bowsers supported on parking legs unless these legs are resting on made-up roadway or concrete of known and adequate thickness, or are resting on a support of suitable size and thickness, to support the loaded weight of the bowser without it sinking into the ground and becoming unstable.</p>
<p><b>3.4.3</b> It should not be assumed that existing sites are correctly sited, even if no pollution problems have arisen. No site should extend to within 10 metres of a <b>watercourse</b> or a drain leading to a <b>watercourse</b>.</p>	

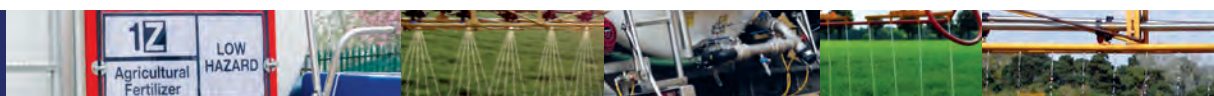

<p><b>3.4.9</b> The <b>user</b> has a responsibility to consider and advise on the correct siting of any tankers or bowsers, including those supplied by a haulier or application contractor. The <b>user</b> should take into consideration the location of surface water drains and land drains. The <b>user</b> must take care to ensure that when laden tankers or bowsers are being moved on their property they are not driven so close to a <b>watercourse</b> or causeway that the bank is unable to support the weight. Weak bridges must be avoided.</p>	<p><b>3.5.5</b> All outlet/inlet valve(s) and sight tubes/gauges should be positioned or protected so that they are not vulnerable to vandalism or accidental damage, particularly from passing vehicles. All valves should be inoperable when unattended, and on bunded tanks should be wholly within the bund. Sight tube valves/gauges should be fitted, closed and locked when not in use, and inside any bund.</p>
<p><b>3.4.10</b> <b>Fluid fertiliser</b> stores should be sited away from public access to minimise the risk of vandalism, with the outlet(s) and sight gauges securely locked or inoperable when unattended. The stores should be made as secure as feasible, with consideration given to deterrent lighting.</p>	<p><b>3.5.6</b> With the exception of aqueous ammonia, <b>fluid fertilisers</b> may be stored in lagoons suitably designed and constructed with impermeable walls, floor and cover.</p>
<p><b>3.5 FLUID FERTILISER STORAGE</b></p>	<p><b>3.5.7</b> Users should conduct a thorough, formal and recorded check of all tanks, bowsers and lagoons at least once a year, in addition to normal everyday observation, for damage or corrosion which might give rise to leakage or failure. Appropriate measures should be taken to repair the storage if necessary and records kept of all inspections and repairs. Advice on inspection and maintenance should be sought from the <b>supplier</b> of the <b>fluid fertiliser</b>.</p>
<p><b>3.5.1</b> <b>Fluid fertilisers</b> may be stored in suitable above-ground tanks or, with the exception of aqueous ammonia, in suitably designed lagoons (see 3.5.6). They should not be stored in unsupported flexible containers.</p>	<p><b>3.6 DELIVERIES AND TRANSFERS</b></p>
<p><b>3.5.2</b> Permanently-sited tanks and fittings must be fit for the purpose, must be of a suitable material resistant to corrosion and must be sited on a base or footing designed to support the weight of the full tank. <b>New and replacement installations should have permanent bunding or an appropriate secondary containment system installed.</b></p>	<p><b>3.6.1</b> A tanker driver delivering <b>fluid fertiliser</b>, who considers the condition of the store, valves, pipework, access or siting inappropriate, should refuse to off-load the delivery.</p>
<p><b>3.5.3</b> The outside of steel tanks should be protected against corrosion with a suitable paint.</p>	<p><b>3.6.2</b> The <b>user</b> should be satisfied that the <b>supplier</b> of <b>fluid fertiliser</b> is operating in accordance with this Code, Part 1, [Suppliers], and has drawn up adequate emergency procedures for use in the event of a <b>major spillage</b> occurring during <b>fluid fertiliser</b> transfer onto farm. The <b>user</b> should ensure that they are able to assist as necessary to contain any spillage and to avoid pollution of any <b>watercourse</b> or <b>groundwater</b>. Routinely supply and use drip trays.</p>
<p><b>3.5.4</b> Tankers, mobile tanks or bowsers should be fit for the purpose and should be of a suitable material resistant to corrosion. All hatches should have covers which provide a watertight seal when closed. No laden mobile tank or bower should be moved unless all hatches, lids and valves are securely closed.</p>	<p><b>3.6.3</b> The <b>user</b> should draw up procedures for use in the event of a <b>major spillage</b> occurring on farm at times other than during delivery by the <b>supplier</b>. These procedures may involve the assistance of the <b>supplier</b> and of the appropriate environment agency. An emergency plan could usefully include drainage and potential containment points.</p>



**3.6.4** The **user** should ensure that, if **fluid fertiliser** is to be delivered into a mobile bowser or road tanker supported on parking legs, these legs are resting on a made-up roadway or concrete of known and adequate thickness, or on a support of suitable size and thickness, to carry the loaded weight of the bowser without it sinking into the ground and becoming unstable.

**3.6.5** All hatches, lids and valves should be securely closed before tankers or bowsers are moved, and valves should be inoperable or locked when unattended.

**3.6.6** Tankers or bowsers should not be filled to capacity, so as to allow for the expansion of contents in warm weather.

**3.6.7** While ideally **users** should be present during deliveries, they should ensure that, in their absence, the delivery tanker driver is able to operate all relevant valves so that they can nevertheless remain in-operable before and after delivery.

**3.6.8** The person undertaking any transfer of **fluid fertiliser** must be aware of all relevant procedures and be capable of taking appropriate action in the event of an incident. They shall remain present and monitor pipework and the receiving tank at all times during the transfer of **fluid fertiliser**. Drip trays should be used where available.

**3.7 EMERGENCY PROCEDURES FOR DEALING WITH A SPILLAGE INCIDENT AT THE USER'S SITE, (TANKER, BOWSER OR STORAGE TANK):**

**3.7.1** Take appropriate action to minimise the spillage and to prevent the pollution of **watercourses/ groundwater**, perhaps using earth barriers/dams. Do not wash down with water unless specifically advised to do so. Immediately contact the appropriate environment agency, or contact the **supplier** of the fertiliser and your employer (if not self-employed) and request that the appropriate environment agency be informed. Remain on site until released by the fertiliser supplier/your employer.

**3.7.2** In the event of a minor spillage such as a leaking hose or valve the procedure should be as follows:

- wearing goggles and gloves, stop the leak,
- where practicable contain the spillage and mop it up. Do not wash down with water unless specifically advised to do so.
- effect repair if possible or inform employer/supplier

Tel No. .... 01526 396000 .....

**3.7.3** Records should be kept of all reported incidents involving spillage resulting from any major spillages occurring at the site.

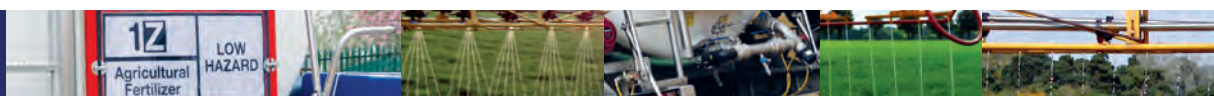

## APPENDIX 1

### SOURCES OF INFORMATION

#### **Containment Systems for the Prevention of Pollution:**

Secondary, tertiary and other measures for industrial and commercial premises. CIRIA (C736)  
[www.ciria.org.uk](http://www.ciria.org.uk)

#### **Protecting our Water, Soil and Air: a Code of Good Agricultural Practice for Farmers, Growers and Land Managers, Defra, 2009.**

The Stationery Office, ISBN 978 0 11 243284 5  
[www.gov.uk/government/publications/protecting-our-water-soil-and-air](http://www.gov.uk/government/publications/protecting-our-water-soil-and-air)

#### **Prevention of Environmental Pollution from Agricultural Activity**

The Scottish Government, 2005, ISBN 0 7559 4106 3.  
[www.scotland.gov.uk/Publications/2002/06/14968/7848](http://www.scotland.gov.uk/Publications/2002/06/14968/7848)

#### **Code of Good Agricultural Practice**

DARD, 2008, ISBN 978 1 84807 068 4.  
[www.dardni.gov.uk/cogap](http://www.dardni.gov.uk/cogap)

#### **Fertiliser Manual (RB209) 8th Edition, 2010**

The Stationery Office, ISBN 978 0 11 243286 9  
[www.gov.uk/government/publications/fertiliser-manual-rb209](http://www.gov.uk/government/publications/fertiliser-manual-rb209)

#### **SRUC Technical Notes: Fertiliser Series**

[www.sruc.ac.uk](http://www.sruc.ac.uk)

#### **Eurocode 2. Design of concrete structures. Liquid retaining and containing structures**

BS EN 1992-3:2006  
[www.techstreet.com/products/1278297](http://www.techstreet.com/products/1278297)

#### **Groundwater protection: Principles and practice (GP3)**

[www.environment-agency.gov.uk/research/library/publications/144346.aspx](http://www.environment-agency.gov.uk/research/library/publications/144346.aspx)

#### **Recommendations for Safe Storage and Handling of Wet Process Phosphoric Acid, (Phosphoric Acid Produced from Sulphuric Acid), 1991**

EFMA, Avenue E Van Nieuwenhuysse 4, B-1160, Brussels  
[www.fertilizerseurope.com](http://www.fertilizerseurope.com)

#### **Hazardous Properties of Ammonia, 1990**

EFMA, Avenue E Van Nieuwenhuysse 4, B-1160, Brussels  
[www.fertilizerseurope.com](http://www.fertilizerseurope.com)

#### **Code of Practice for the Prevention of Water Pollution from the Storage and Handling of Solid Fertilisers**

Agricultural Industries Confederation, 2009, Confederation House, East of England Showground, Peterborough, PE2 6XE  
[www.agindustries.org.uk](http://www.agindustries.org.uk)

#### **Guidance for the Preparation of Safety Data Sheets for Fertilizer Materials 2008**

EFMA, Avenue E Van Nieuwenhuysse 4, B-1660, Brussels  
[www.fertilizerseurope.com](http://www.fertilizerseurope.com)

#### **FACTS**

For details of the FACTS Scheme and its qualified advisers in crop nutrition  
Tel: 01335 343945  
[www.basis-reg.com/facts](http://www.basis-reg.com/facts)

#### **THE ENVIRONMENT AGENCY ENGLAND**

Free emergency incident telephone number: 0800 80 70 60  
General enquiries: 03708 506506  
[www.environment-agency.gov.uk](http://www.environment-agency.gov.uk)

#### **NATURAL RESOURCES WALES**

Free emergency incident telephone number: 0800 807060  
General enquiries: 0300 065 3000  
[www.naturalresourceswales.gov.uk](http://www.naturalresourceswales.gov.uk)

#### **SEPA**

Free emergency incident telephone number: 0800 807060  
[www.sepa.org.uk](http://www.sepa.org.uk)

#### **NORTHERN IRELAND ENVIRONMENT AGENCY**

Free emergency incident telephone number: 0800 80 70 60  
[www.doeni.gov.uk](http://www.doeni.gov.uk)



# FLUID FERTILISER STORAGE TANK ENVIRONMENTAL RISK ASSESSMENT FOR SPILLAGES

This assessment should be completed for all existing or proposed installations

## Storage tank sited at

(use field or yard name if relevant)

Tank owner

Owner's address

(if different from location)

Date of assessment

Assessed by

Tank construction *(delete as appropriate)*: GRP/Steel/Other (please specify)

Max tank capacity

litres

gallons

Manufactured by

Date manufactured

Date installed

Maintained and serviced by

HAZARD	√ YES HIGHER RISK	x NO LOWER RISK
Tank situated where any spillage could enter an open drain, gully or loose fitting manhole cover draining to a ditch, watercourse, lake, pond, land drains or soakaway?		
Is the tank situated over ground or a hard surface that would convey any spillage into a ditch, watercourse, lake, pond, land drains, soakaway or to within 50 metres of a borehole, well or spring?		
Is the tank situated on a free draining, permeable surface?		
Is the tank situated in a position where it can not be observed during delivery or take off?		
Are there any other potential hazards individual to the site that could result in unacceptable environmental damage?		

One or more ticks in the Yes column indicate that the storage tank is at a higher risk. You are recommended to ensure that the tank is provided with adequately designed and constructed secondary containment system which should also enclose ancillary equipment such as the fill and draw off pipework connections.



# TANK INSPECTION CHECKLIST

Tank Location: \_\_\_\_\_

CHECK	Condition score			Repair required		Comments
	1	2	3	Yes	No	
Visible external corrosion						
Visible corrosion of welded seams						
Plastic tanks damaged, cracked or crazed						
Damp areas on outside of tanks (These may indicate pinhole leaks)						
Tank label						
Condition of inlet valve	Internal					
	External					
Condition of outlet valve	Internal					
	External					
Condition of glass support						
Condition of sight of glass valves						
Condition of tank paint work						
Security locks on fittings: (Inlet/outlet valves, delivery hatches, vent pipes and sight glass valves)						
<b>Total Score</b>						

## Secondary Containment System Inspection Checklist (if installed)

CHECK	Condition score			Repair required		Comments
	1	2	3	Yes	No	
Floor of secondary containment system						
Walls of secondary containment system						
Roof of secondary containment system						
Housekeeping inside secondary containment system)						
Drainage outlet						
Adequate to contain 110% capacity of tank						
<b>Total Score</b>						

**Secondary Containment System:** An impermeable structure around a storage tank and ancillary equipment to allow the contents of the tank to be contained should a leak or spill occur. These systems may take various forms. For example: earth embankments, a brick bund or a metal bund. The ideal capacity of a secondary containment system should be a minimum of 110% of the tanks capacity.

### Tank Inspection Score Indicators

Score	Priority	Condition
1-13	No repairs required	1
13-26	Some repairs required	2
26-39	Immediate repairs required	3

### Secondary Containment System Inspection Score Indicators

Score	Priority	Condition
1-6	No repairs required	1
6-12	Some repairs required	2
12-18	Immediate repairs required	3

### Guidelines for Action

Condition	Examples of faults found
1	Near perfect condition: Paint intact, no paint blisters. No corrosion of tank or valves. No cracks in secondary containment. Tanks supports in good condition. Tank is clearly labelled. Locks on all fittings, eg inlet and outlet valves and sight glass valve. No drainage outlet. No repairs required.
2	Adequate condition: Paint system flaking, but still adequate. Slight corrosion of tanks and valves. Some cracks in secondary containment system. Slight cracking around supports. Label is unclear or in wrong position. Locks only on some fittings. External drainage outlet with control valve. Some repairs required.
3	Bad condition: Paint system flaking badly, pitted or corroded; paint system ineffective. Tank and valves corroded. Secondary containment system badly cracked and retaining liquid. Cracked tank supports. Tank unlabelled. No security locks fitted. Bund ineffective. Immediate repairs required.

Signature: \_\_\_\_\_

Date: \_\_\_\_\_

# Notes

A series of horizontal dotted lines for writing notes.



OMEX Agriculture  
Bardney Airfield  
Tupholme  
Lincoln  
LN3 5TP  
Tel 01526 396000

Email [contact@omex.com](mailto:contact@omex.com)  
Web [www.omex.com](http://www.omex.com)

